





1967

CORVETTE

SPECIFICATIONS

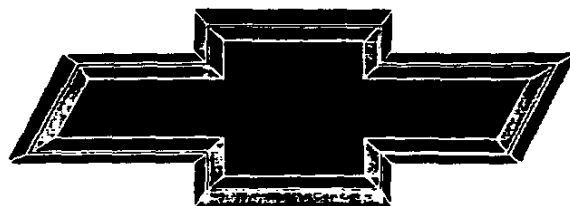
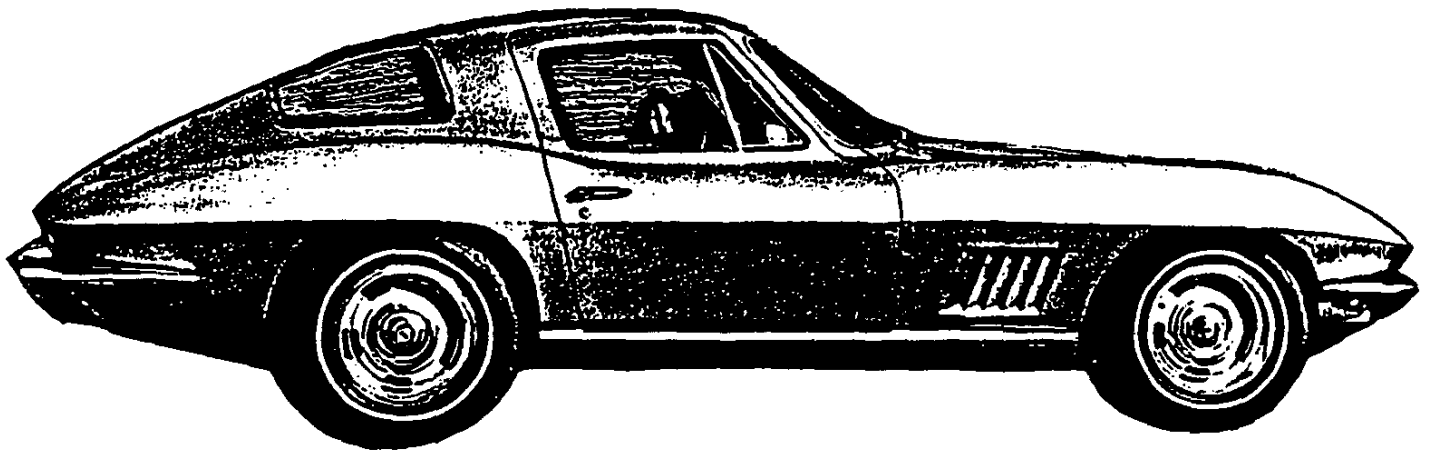

GENUINE CHEVROLET™



✓

✓

✓

✓

✓

✓

✓

✓

✓

✓

✓

✓

✓

✓

✓

✓

✓



ORIGINAL

GENERAL

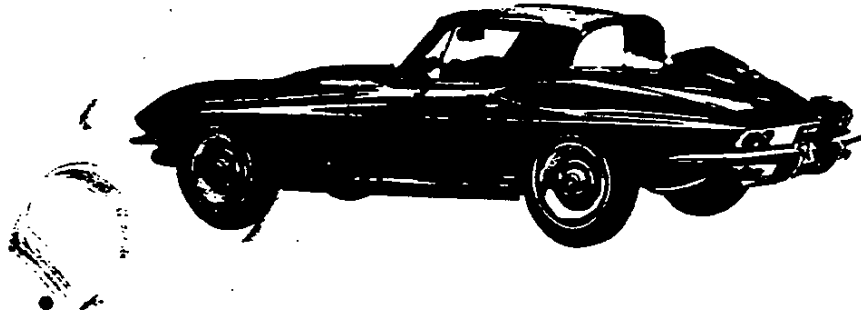

MODEL IDENTIFICATION	2
SERIAL NUMBERS AND IDENTIFICATION	3
REGULAR EQUIPMENT - EXTERIOR	4
REGULAR EQUIPMENT - INTERIOR	5
REGULAR PRODUCTION OPTIONS AND DEALER INSTALLED ACCESSORIES	6
AIR CONDITIONING EQUIPMENT	7

MODEL IDENTIFICATION

CORVETTE 19437 SPORT COUPE
MODEL 19437 2-DOOR SPORT COUPE, 2-PASSENGER

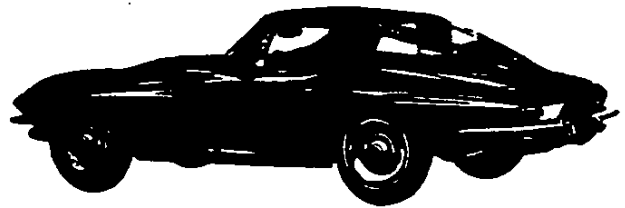

CORVETTE 19467 CONVERTIBLE
MODEL 19467 2-DOOR CONVERTIBLE, 2-PASSENGER

SERIAL NUMBERS AND IDENTIFICATION

ONLY BASIC DESIGNATIONS SHOWN

VEHICLE SERIAL NUMBER

Example:

Model	Model Year	Assembly Plant (St. Louis)	Unit Number (25th Unit)
19437	7	S	100025

Thus: The 25th model built at St. Louis would be serial number 194377S100025

ASSEMBLY PLANT

S - St. Louis

Starting unit number ----- In numerical sequence beginning with 100001
 Location ----- On plate, R.H. side of hinge pillar cross brace under glove

ENGINE IDENTIFICATION

Example: F 1210 HE

Source Designation	Production Month and Date	Type Designation
F (Flint)	1210	HE

327 Cubic inch V-8

HE - Regular production engine
 HT - RPO L79 4-barrel, hyd. lifters

427 Cubic inch V-8

IL - RPO L36, 4-barrel, hyd. lifters
 JC - RPO L68, 3 x 2-bbl. carbs., hyd. lifters
 JE - RPO L71, 3 x 2-bbl. carbs., mech. lifters

Location ----- Stamped on top front of RH bank of cylinder and case

• TRANSMISSION IDENTIFICATION

Example: S7E01

Prefix	Plant	Production Month & Date	Type Designation
S	Saginaw	501D ^a	3-speed
R	Saginaw		4-speed
P	Muncie		4-speed
C	Cleveland		Powerglide
T	Toledo		Powerglide

Location:
 3-Speed & 4-speed ----- Stamped on right hand side of the case in the upper forward corner.
 4-Speed ----- Stamped on the top right side of the case.
 Powerglide ----- Stamped on right hand side of pan.

- o - Month: 5 denotes May; 01 denotes 1st day.
- - The letter "D" or "N" following the date numerals, indicates day or night shift.

REAR AXLE IDENTIFICATION

Example: AK 0212 W

Type Designation	Production Month and Day	Source Designation
AK	0212	W(Warren)

Regular axles

AK	3.36:1
AS	3.70:1

Positraction axles

AL	3.08:1
AM	3.36:1
AN	3.55:1
AO	3.70:1
AP	4.11:1

Location ----- Bottom edge of differential carrier flange

REGULAR EQUIPMENT—EXTERIOR

Bright Metal Surfaces	Body sill molding (black paint fill)		All	
	Bumpers, front and rear			
	Door handles and key locks			
	Gas filler door and bezel			
	Radiator grille			
	License plate bezel, rear			
	License plate frame, front and rear			
	Outside rear view mirror, left hand door			
	Parking and direction signal lamp bezels			
	Rear window reveal			19457
	Tail pipe extensions and bezels			All
	Tail, stop and direction signal lamp bezels			
	Vent window frames			19467
	Windshield pillar molding			
Windshield reveal moldings				
Wheel trim rings and hub caps				
Emblems	Crossed	Body front panel	All	
	Flags	Gas filler door		
	Nameplates	Rear deck		
Exterior Lighting	Headlamps, dual, retractable		All	
	Parking and direction signal lamps (amber lenses)			
	Rear license lamp			
	Tail, stop direction signal and back-up lamps			
Front fender louvers			19467	
Integral front and rear bumper guards				
Manual folding top				
Spare tire well cover lock				All

REGULAR EQUIPMENT—INTERIOR

Bright Metal Surfaces	Direction signal control lever (with lane change signal)	All	
	Floor tunnel cover plate & molding		
	Glove box door trim plate, emblem and molding		
	Instrument cluster trim molding and control knobs		
	Instrument panel console control knobs		
	Rear view mirror and support (day-night padded)		
	Seat adjustment handle		
	Seat backrest side trim		
	Seat belt keeper plates		
	Body and rocker panel sill plates (black fill)		
	Steering wheel spokes and horn button bezel		
	Seat back lock handle		
	Top header release latches		19467
	Transmission shift lever and knob		All
Transmission shift lever bezel, ash tray door, shift pattern diagram, and parking brake lever			
Windshield upper and side garnish moldings	19467		
Seat belt buckles			
Door closing handle			
Door locking knob			
Door opening handle with ball-shaped knob (free-wheeling)			
Door side window crank handle and plastic knob			
Door vent window crank handle			
Door trim panel molding and plastic knob			
Bucket seats with individual fore-aft adjustment	All		
Compound curved door glass			
Cowl vents (on instrument panel console)			
Direction signal control			
Door trim panel with built-in armrest			
Electric clock with second hand (on instrument panel console)			
Heater controls (on instrument panel console)			
Hood release control			
Instrument Cluster		Ammeter, temperature, fuel and oil pressure gauges	
		Cigarette lighter	
		Clock	
		Direction signal indicators	
		Headlamp hi-beam indicator	
		Headlamp position warning indicator	
	Headlamp rotation switch		
	Ignition lock and starter switch - "4 position"		
	Main light switch		
	Parking brake and brake system failure indicator		
	Simulated vinyl trim plate		
	Speedometer (160 mph) with trip odometer		
	Tachometer (7000 rpm)		
Windshield washer and wiper control switch	19437		
Interior Lighting	Dome	All	
	Glove compartment		
	Heater controls		
	Instrument cluster controls and gauges		
	Instrument panel courtesy, left and right		
Rear compartment courtesy	19467		
Four-way hazard flasher	All		
Padded sunshades and instrument panel hoods	19437		
Padded headlining with sunshade recessions	All		
Parking brake lever (on center console, black handle)			
Passenger compartment carpeting, molded			
Rear compartment carpeting, molded			
Seat belts, push-button with retractors & stowage provisions			
3-spoke steering wheel and horn button (simulated wood grain)			

**REGULAR PRODUCTION OPTIONS AND
DEALER INSTALLED ACCESSORIES**

Equipment	RPO/ACC	Models
Air conditioning, Four-Season	C60	19400
Air injection reactor equipment	K19	19400
Brakes, heavy duty	J56	19400
Brakes, power	J50	19400
Carrier, deck lid luggage		ACC 19467
Carrier, ski equipment (deck lid)		ACC 19467
Carrier strap, luggage		ACC 19400
Compass, auto		ACC 19400
Cylinder heads, aluminum	L89	19400
Emergency road kit		ACC 19400
Engines		
390 hp Turbo-Jet 427 Cu.in. V-8	L36	19400
400 hp Turbo-Jet 427 Cu.in. V-8	L68	19400
435 hp Turbo-Jet 427 Cu.in. V-8	L71	19400
350 hp Turbo-Fire 327 Cu.in. V-8	L79	19400
Exhaust system, off-road service	N11	19400
Exhaust system, side-mounted dual	N14	19400
Fire extinguisher		ACC 19400
Floor mats, clear vinyl twin		ACC 19400
Glass, tinted window	A01	19400
Glass, tinted windshield	A02	19400
Headrest, conventional type front seat	A82	19400
Heater-defroster deletion	C48	19400
Ignition system, full-transistor	K66	19400
Lock, gas tank filler cap		ACC 19400
Radio and rear antenna, push-button AM-FM	U69	ACC 19400
Radio antenna, rear (fixed height)		ACC 19400
Radio ignition shielding equipment		ACC 19400
Rear axle - Positraction	G81	19400
Roof cover, vinyl	C08	19467
Seat pad, ventilated		ACC 19400
Shoulder harness, front seat	A85	19400
Speed warning indicator	U15	19400
Spotlamp, hand portable		ACC 19400
Steering, power	N40	19400
Steering shaft, telescopic	N36	19400
Suspension, special performance front and rear	F41	19400
Tires		
7.75-15-4pr whitewall rayon	P92	19400
7.75-15-4pr special nylon - red stripe	QB1	19400
Top, auxiliary	C07	19467
Top, folding convertible	C05	19467
Transmissions		
4-speed transmission (2.32:1 low)	M20	19400
4-speed transmission close ratio (2.38:1 low)	M21	19400
Powerglide transmission (1.76:1 low)	M35	19400
Wheels, mag-style aluminum	N89	19400
Windows, power	A31	19400

AIR CONDITIONING EQUIPMENT

FOUR-SEASON (RPO C60)

Heater integrated; manually controlled by knobs on instrument control panel, that operate bowden cables to activate various doors and switches to operate system.

BASIC COMPONENTS

Evaporator, blower, condenser, receiver-dehydrator, refrigerant (freon) tank, air intake assembly and duct assembly for both systems.

EQUIPMENT (Used in addition to or in place of base equipment)

CHASSIS

Front and Rear Springs ----- Heavy duty
Rear Axle Ratio - Refer to Power Trains Section

POWER TRAINS

Fan Blade ----- 5 blade
Crankshaft Pulley ----- Dual
Water Pump & Fan Pulley ----- Dual
Compressor & Crankshaft Belt ----- One*
Generator ----- 61 Ampere

* Additional equipment; also brackets, supports, braces, hoses, etc. as required for installation.

Heavy duty cooling equipment must be used on V-8 powered vehicles. It is recommended that this equipment also be used on all other vehicles for securing maximum air conditioning performance.

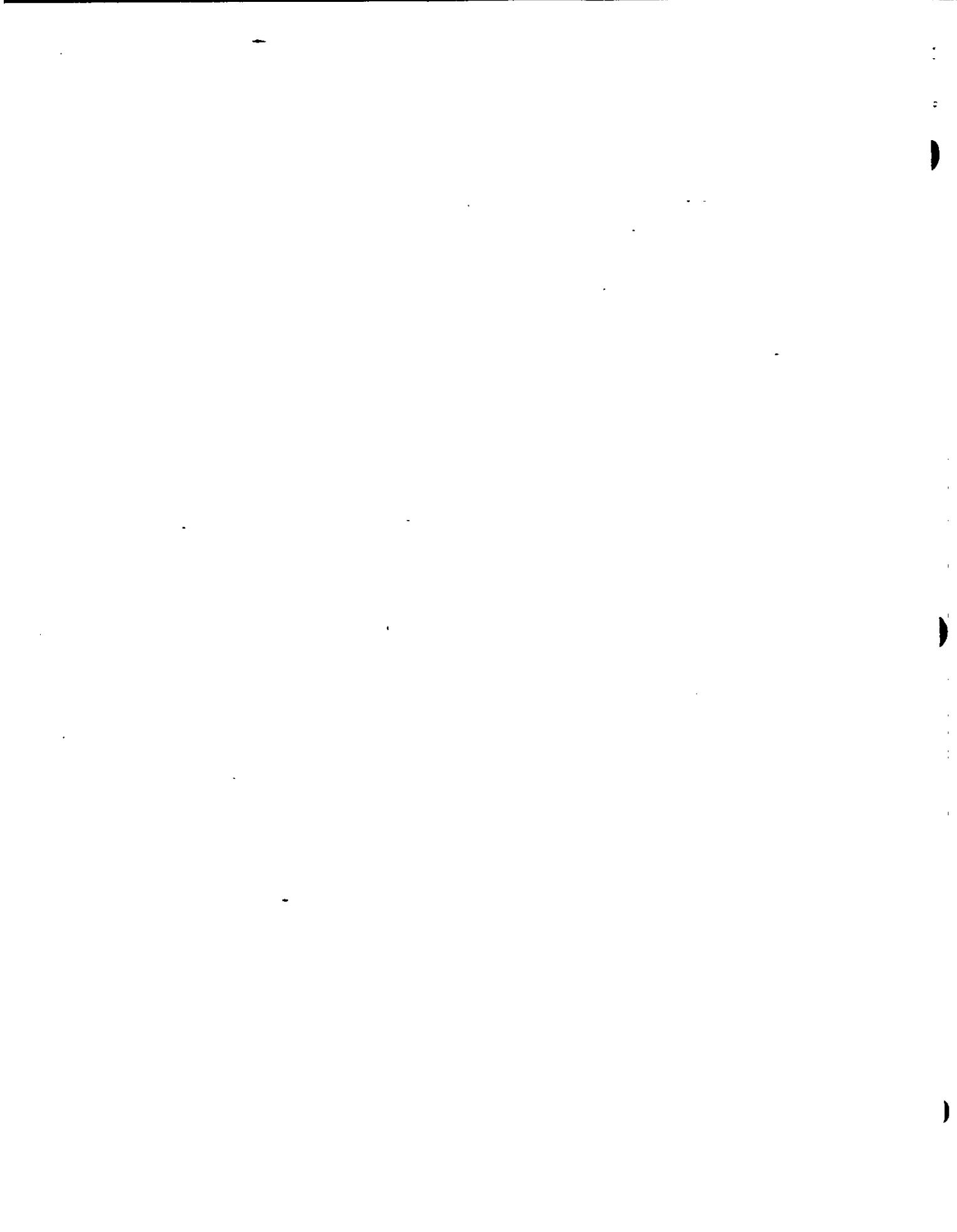

DIMENSIONS AND WEIGHTS

INTERIOR DIMENSIONS	2
EXTERIOR DIMENSIONS	3
VEHICLE WEIGHTS	4

INTERIOR DIMENSIONS

FRONT COMPARTMENT

CODE	DESCRIPTION	19437	19467	19467
		COUPE	SOFT TOP	HARDTOP
H5	H point to ground		15.4	
H30	H point to heel point		7.3	
H37	Headlining to roof height	.4	—	.3
H54	D point to tunnel		1.9	
H58	H point rise		.3	
H61	Effective headroom	37.0	38.5	37.2
H65	D point differential, side to center		13.1	
H67	Depressed floor covering thickness		.3	
H70	Body zero line to H point (vert.)		7.7	
L17	H point travel		4.0	
L31	Body zero line to H point (horiz.)		44.5	
L34	Maximum effective leg room - accelerator		42.7	
L40	Back angle (degrees)		28	
L42	Hip angle (degrees)		102	
L44	Knee angle (degrees)		135	
L46	Foot angle (degrees)		82	
L53	H point to accelerator floor point		35.8	

SEAT AND ENTRANCE

H3	Seat chair height		9.0	
H11	Entrance height	31.4		30.2
H26	Interior body height, M/M @ car centerline	36.2	36.9	35.8
H27	Interior body, M/M @ C/LO	40.7	41.6	40.6
H32	Seat cushion deflection		3.1	
H50	Upper body opening to ground	46.8		45.6
W1	Hat room	45.1		39.3
W3	Shoulder room		48.4	
W5	Hip room		46.9	
W16	Seat width (each seat)		20.6	
L14	Seat back thickness		3.9	
L18	Entrance foot clearance		16.5	

VISION AND CONTROL

H6	H point to W/S bottom DLO		19.9	
H13	Steering wheel thigh clearance		4.5	
H18	Steering column angle (degrees) horizontal		16	
H25	Belt height		18.0	
H49	H point to top of steering wheel		22.8	
H64	H point to W/S upper DLO		30.6	
W7	Steering wheel center to car centerline		12.8	
W9	Steering wheel maximum O.D.		16.0	
W122	Tumble-home (degrees)		20.0	
L7	Steering wheel torso clearance		13.2	
L13	Brake pedal knee clearance		24.6	
L49	H point to W/S upper DLO		16.4	
L52	Brake pedal to accelerator		2.8	

EXTERIOR DIMENSIONS

LENGTHS

CODE	DESCRIPTION	19437	19467	19467
		COUPE	SOFT TOP	HARDTOP
L101	Wheelbase		98.0	
L102	Tire size (standard)		7.75 x 15	
L103	Overall length		175.1	
L104	Overhang - front		31.9	
L105	Overhang - rear		45.2	
---	Overall length - less bumpers			
L123	Body upper structure length at car C/L	77.9	66.8	69.2
L127	Body O line to C/L of rear wheels		72.0	
L128	Hood length at centerline		46.7	
L129	Deck length @ car C/L	28.6	39.7	37.3
L130	Body zero line to W/S cowl point		9.0	

WIDTHS

W101	Tread - front		57.6
W102	Tread - rear		58.3
W103	Maximum overall width of car (W106)		69.6
W106	Front fender overall width		69.6
W107	Rear fender overall width		67.3
W120	Overall car width, front doors open		139.3
W122	Tumble-home (degrees)		20

HEIGHTS

H101	Overall height (design)	49.6	49.8
----	Overall height (curb)	51.2	51.4
H102	Front bumper to ground		10.3
H104	Rear bumper to ground		10.8
H111	Rocker panel to ground - rear		8.0
H112	Rocker panel to ground - front		8.0
H114	Hood at rear to ground		34.8
H115	Step height - front (design)		13.9
H122	W/S slope angle (degrees)		56
H125	Headlamp to ground		24.4
H126	Tail lamp to ground		21.2
H130	Step height - front (curb)		16.0
H132	Bottom of door to ground - open		13.5
H133	Bottom of door to ground - closed		12.5
H136	Body O line to ground - front		7.7
H137	Body O line to ground - rear		7.7
H138	Roof thickness	3.7	4.4
H159	DLO height	12.5	12.2
H160	Body thickness		25.5

CLEARANCES

H106	Angle of approach (degrees)		26
H107	Angle of departure (degrees)		17
H147	Ramp breakover angle (degrees)		12
H148	Front suspension to ground		8.0
H149	Oil pan to ground		6.0
H150	Flywheel housing to ground		5.9
H151	Frame to ground		5.5
H152	Exhaust system to ground		5.0
H153	Rear axle to ground		7.8
H154	Fuel tank to ground		Mounted over tire well
H155	Tire well to ground		6.1
H156	Minimum ground clearance (H152)		5.0
S1	Windshield glass area (sq.in.)		789.7

VEHICLE WEIGHTS

CORVETTE

Model	VEHICLE TYPE Description	SHIPPING WEIGHT			CURB WEIGHT		
		Front	Rear	Total	Front	Rear	Total
19437	2-Door Sport Coupe 8-cylinder	1560	1440	3000	1555	1600	3155
19467	2-Door Convertible 8-cylinder	1540	1480	3020	1535	1640	3175

SHIPPING WEIGHT: Weight of basic vehicle with regular equipment and grease and oil. Weight of gasoline and water not included.

CURB WEIGHT: Weight of empty vehicle ready to drive. Shipping weight plus the weight of gasoline and water.

For total shipping, and curb, weights of vehicles equipped with the following options, add to, or deduct from, the base vehicle weight (lbs).

RPO	Option	Weight
A31	Power Windows	+ 5
C07	Auxiliary Top	+ 49
C48	Less Heater	- 20
C60	Air Conditioning	+ 93
J50	Power Brakes	+ 12
J56	Heavy Duty Brakes	+ 6
L89	Aluminum Cylinder Heads	- 73
M20	Four-Speed Transmission	- 5
M35	Powerglide Transmission	+ 1
N40	Power Steering	+ 21
U69	Radio - AM-FM Push-Button	+ 21
● L79	327 Cu.In. V-8 350 H.P.	- 8
● L86	427 Cu.In. V-8 390 H.P.	+215
● L68	427 Cu.In. V-8 400 H.P.	+151
● L71	427 Cu.In. V-8 435 H.P.	+149

BODY

EXTERIOR PAINT	2
EXTERIOR-INTERIOR COLOR COMBINATIONS	3
BODY CONSTRUCTION AND GLASS AREA	4

EXTERIOR PAINT PROCESS

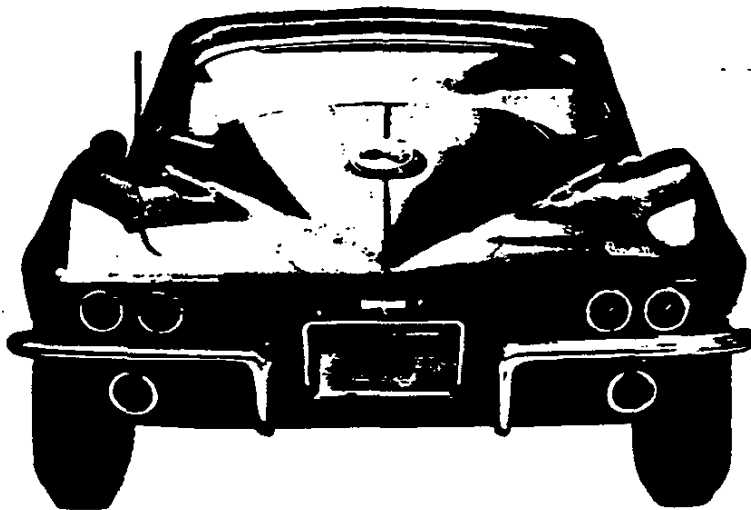

1. **PRIMARY SANDING.** All body panels and bonded joints that receive acrylic lacquer are dry sanded to prepare surfaces for painting. A filler material, called putty rub, is applied to the entire body to fill minor imperfections.
2. **PRIMER.** Two coats of primer are applied -- the first red and the second gray -- and are oven baked for 60 minutes at 280 degrees F.
3. **WET SANDING.** The body is wet sanded to provide a smooth surface for the sealers. Most of the gray primer coat is removed with the red primer acting as a depth signal for the sanding operation. The body is dried to remove all moisture.
4. **SEALER.** One coat of sealer and one coat of color acrylic lacquer are applied and baked.
5. **DRY SANDING.** The body is dry sanded to prepare surfaces for the final acrylic lacquer.
6. **LACQUERING.** Three coats of acrylic lacquer are sprayed on the body to build up the required paint thickness. The paint is "rested" for eight minutes to permit it to partially set up and to remove excess volatile paint vehicle.
7. **INITIAL BAKING.** The body is oven baked for 30 minutes at 140 degrees F to harden the paint which permits the subsequent operation. Small interior and exterior parts are painted to complete the body paint schedule.
8. **FINAL BAKING.** To assure a durable, hard, high luster finish the lacquer is oven baked for 45 minutes at 250 degrees F. Reheating the lacquer permits the paint film to soften and allows surface blemishes and sanding scratches to disappear during the thermo-reflow process.
9. **FINAL SANDING AND POLISHING.** The body is lightly oil sanded and polished to bring painted surfaces to a high luster finish.

EXTERIOR-INTERIOR COLORS

CORVETTE

		INTERIOR TRIM COLORS AND RPO NUMBERS							
		Black	Red	Med. Brt. Blue	Med. Saddle	White Med. Brt. Blue	Dark Green	Dark Teal Blue	White Black
		Models 19437-67							
EXTERIOR		Reg. Prod.	407	414	420	450	430	418	455
RPO	Color	402°	408°	415°	421°	---	---	419°	---
900	Black	X	X	X	X	X	X	X	X
972	White	X	X	X	X	X	X	X	X
974	Red	X	X						X
976	Med. Brt. Blue	X		X		X			
977	Dk. Teal Blue	X						X	X
980	Silver Blue	X						X	
983	Dk. Green	X			X		X		X
984	Yellow	X							X
986	Silver	X						X	
988	Maroon	X			X				X

Convertible top: Black standard, white, or optional dark teal blue with any exterior color.

* Genuine leather seat trim option.

BODY CONSTRUCTION AND GLASS AREA

GENERAL

Construction ----- Uniconstruction: fiber glass reinforced plastic body backboned by a steel cage outlining the passenger compartment. Principal members — underbody, front and rear end assemblies, dash panel, roof (Model 437) and hinge pillars are bonded, riveted, or bolted together and to each other. Hood is plastic with bonded plastic reinforcement.

VENTILATION

Type ----- "Saddlebag" cowl top air inlets channel air to cowl side kick panel outlets controlled by bowden cable and slide type levers mounted in instrument panel center console. Water drainage at base of "saddlebag" plenum chambers.

SEATS

Type and construction ----- Bucket; leather grained vinyl covering over polyurethane padding

DOORS AND LOCKS

Construction ----- Plastic, double paneled, reinforced with steel at hinge and lock locations. Front hinged.

Door handles ----- Push-button with rotary type latches. Inside door locking knob on each door, free-wheeling 2-position inside door handles; upper reflector on side wall trim

Door ventpanes operation ----- Crank

WINDSHIELD WIPERS

Type ----- Dual, two-speed, electric; washer provided
Linkage ----- Parallel acting

SPARE TIRE

Location ----- In well under fuel tank; accessible from underside of car. Cover with key lock provided.

HOOD

Operation ----- Internal release lever. Front hinged with telescoping link on right side. Ratchet-type lock for hold open.

TOOLS

Type ----- Scissors jack, and combination jack handle and lug wrench
Stowage ----- In well in luggage area directly behind drivers seat; carpeted cover over well

BODY GLASS

LOCATION		TYPE	MODELS	
			19437	19467
Windshield		Curved, 1-piece	789.7	
Side Door	Door	Curved	528.3	442.8
	Ventipane	Curved	91.8	107.3
Back Window	Soft Top	Flat, 1-piece		440.5
	Hardtop	Curved, 1-piece		888.2
	Sport Coupe	Curved, 1-piece	821.5	
Total Visibility			2231.3	Soft Top 1780.3 Hardtop 2228.0

CHASSIS

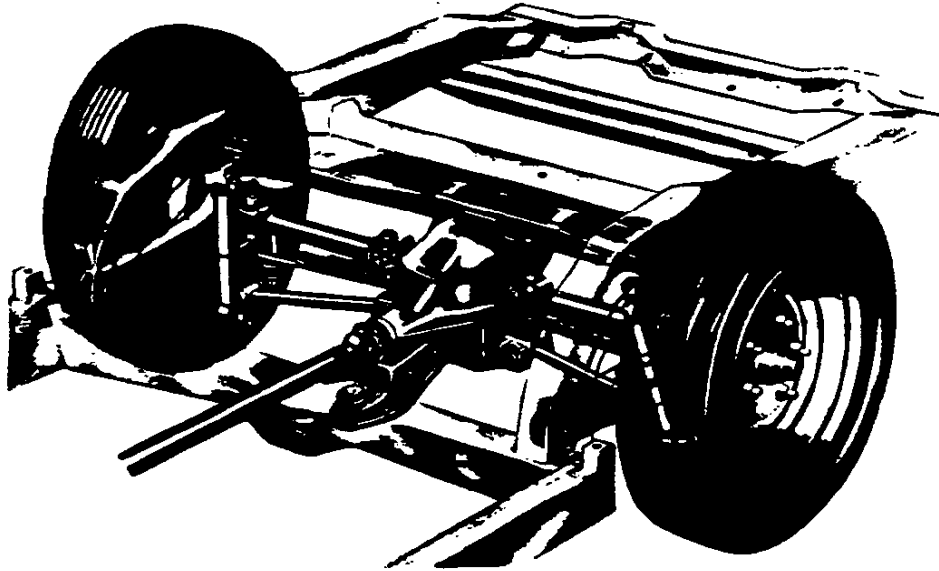

FRAME AND FRONT SUSPENSION	2
STEERING, DRIVELINE, WHEELS AND TIRES	3
REAR AXLE AND SUSPENSION	4
BRAKES	5
BULBS AND LAMPS	6
FUSES AND CIRCUIT BREAKERS	7

FRAME AND FRONT SUSPENSION

FRAME

Description ----- All welded, full length, ladder constructed frame with 5 cross-members. Side rails and intermediate cross-members box section; front crossmember box girder section. Body mounting points; convertibles & hardtop 8, and coupes 6.

FRONT SUSPENSION

Description ----- Independent, SLA type with coil springs and concentric shock absorbers and spherically jointed steering knuckles for each wheel. Adjustments to front suspension are achieved with shims at pivot shafts.

Wheel travel (design) -----
 Total ----- 7.75
 Jounce ----- 3.75
 Rebound ----- 4.00
 Wheel to spring, travel ratio ----- 1.63

CONTROL ARMS

Description ----- Reinforced steel stamping with pre-loaded, steel encased rubber bushings at pivot.

STEERING KNUCKLES

Description ----- Forged steel, with integral caliper brake mounting, and detachable steering knuckle arm

Spindle diameters -----
 Inner bearing ----- 1.2493-1.2498
 Outer bearing ----- .7492-.7497
 Spindle thread size ----- 3/4-20 NEF-3 (modified)
 Wheel bearing -----
 Type ----- Taper roller
 Number ----- Two per spindle

SPHERICAL JOINTS

Type ----- Ball studs, upper self-adjusting for wear
 Bearing surfaces -----
 Upper ----- Two bearings; both non-metallic; teflon-coated phenolic
 Lower ----- One upper surface, teflon-coated phenolic

SHOCK ABSORBERS

Type ----- Direct, double-acting, hydraulic
 Piston diameter ----- 1.00

STABILIZER BAR

Type ----- Link
 Material ----- HR steel
 Diameter ----- 327 V-8, .750; 427 V-8, .875
 Bushing material ----- Natural or synthetic rubber

FRONT WHEEL ALIGNMENT (CURB)

Camber (degrees) ----- P1/4 to P1-1/4
 Caster (degrees) ----- P1/2 to P1-1/2
 Toe-in (total) ----- 3/16 to 5/16
 SAI (degrees) ----- 6-1/2 to 7-1/2

GENERAL SUSPENSION PROVISIONS

Car leveling ----- Front stabilizer bar
 Anti-dive control ----- Angle of front upper control arm
 Driveline alignment ----- Rear control arm shims

● FRONT SPRINGS

Part Number	Ref.	Type	Material	Cut-off Length	Wire Dia.	Inside Dia.	Heights		Deflection Rate (lbs per inch)	
							Free	Working (in. @ lbs)	@ Spring	@ Wheel
3851100	A	Coil, R.H.	AISI A-5160	168.5	.600	3.80	16.82	9.98 @ 1340	195	80
3888250	B	helix		*	.600	3.80	14.26	9.98 @ 1490	*	*

* To be provided

Engine	327 Cu. In. V-8	
	19400	
Models	37	67
Ref.	A	A

	427 Cu. In. V-8	
	B	B

STEERING, DRIVELINE, WHEELS AND TIRES

MANUAL STEERING, regular production

Description ----- Semi-reversible, recirculating ball nut steering gear with energy absorbing steering column, a steering damper mounted on the tie rod and a dual mounting steering arm-tie rod connection for street and fast ratio. Telescopic steering wheel available optionally.

System ratios
 Steering gear ----- 16:1
 Overall ratio
 Street ----- 20.3:1
 Fast ----- 17.6:1

Turning diameters (ft)
 Outside front, wall to wall ----- 41.6
 Outside front, curb to curb ----- 39.9
 Inside rear, wall to wall ----- 25.6
 Inside rear, curb to curb ----- 25.6

Number of wheel turns, lock to lock
 Street ----- 3.4
 Fast ----- 2.92

Outside wheel angle with inside wheel
 @ 15 degrees ----- 14.25
 @ 20 Degrees ----- 18.47
 @ 34 degrees (limit of turn) ----- 27.37

Linkage ----- Parallelogram, rear of wheels, 2 tie rods

Steering wheel
 Standard and optional telescoping wheel ----- Deep dish, 16.0 diameter

POWER STEERING, RPO N40

(Same as standard Manual Steering except as shown)

Description ----- Hydraulic; pump powered cylinder assisting linkage

Ratios ----- Gear, 16:1; overall, 17.6:1
 Number of wheel turns, lock to lock ----- 2.92

DRIVELINE

Type ----- Tubular, exposed
 Number used ----- One
 Diameter (OD) ----- 1.995-2.003
 Length (C/L of U-joints) ----- 29.90
 Wall thickness ----- .092-.097

Universal joints
 Type ----- Cross
 Number used ----- Two
 Bearings ----- Prepack, anti-friction
 Drive and torque ----- Through rear suspension control arms

WHEELS (Regular Production)

Type ----- Short spoke spider
 Attachment to hub ----- 5 hex nuts, 7/16-20 UNF 2-B, arranged on a 4.75 diameter bolt circle
 Offset ----- .06
 Rim size ----- 15 x 6JK

WHEEL, RPO N89

Type ----- Ribbed, cast aluminum
 Attachment to hub ----- 5 hex nuts, 7/16-20 UNF 2-B, arranged on a 4.75 diameter bolt circle
 Offset ----- .06
 Rim size ----- 15 x 6L

TIRES

Construction ----- 2 ply
 Size and ply rating ----- 7.75 x 15-4PR
 Specifications
 @ Static Loaded Radius ----- 12.6
 Loaded rev/mi @ 50 MPH ----- 776
 Capacity (lb @ psi) ----- 1280 @ 24
 Recommended inflation, all tires, psi ----- 24

REAR AXLE AND SUSPENSION

REAR AXLE

Description	Semi-floating, straddle mounted hypoid gear with differential carrier mounted to frame. Differential carrier contains hypoid gear with overhung pinion gear supported by two taper roller bearings
Pinion offset	1.5
Pinion bearing adjustment	Shim
Hypoid gear PD	8.375
Type	Military Spec. MIL-L-2105-B
Viscosity	SAE80
Filler plug	1-3/8 hex, 1-30 AN thread
Capacity (pts)	3.7
Ratios (standard)	
Base engine	3.36
RPO L79	
2.52:1 low	3.36
2.20:1 low	3.70
RPO L36 & L68	
4-speed (2.52:1 low)	3.08
4-speed (2.20:1 low) & Powerglide	3.36
RPO L71	3.55

HYPOID AND PINION GEAR TOOTH COMBINATION

3.08	37,12
3.36	37,11
3.55	32,9
3.70	37,10

AXLE SHAFT

Type	Welded steel tubing incorporating universal joint at each end. Brake drum flange integral with axle which is universally-jointed to axle shaft
Axle bearings	
Type	Tapered roller, 2 per wheel inner and outer bearing seals steel encased rubber

REAR WHEEL

Description	Brake disc flange integral with axle which is universally-jointed (thru splined axle flange) to axle shaft; torque control arm bolted to axle support. Axle supported by two taper roller bearings
-------------	--

REAR SUSPENSION

Description	Full independent with frame-anchored differential. Locus of each wheel established by 3 links: universally-jointed axle drive shaft and adjacent strut, and torque control arm pivoted at frame side rail. Vertical suspension loads taken by shock absorbers and transversely-positioned leaf spring. Built-in camber adjustment at struts
Wheel travel (design height)	
Total	7.17
Jounce	3.17
Rebound	4.00
Wheel to spring, travel ratio	0.90:1

SHOCK ABSORBERS

Type	Direct, double-acting, hydraulic
Piston diameter	1.00

STRUT

Material	Forged steel
Diameter	.75

STABILIZER BAR (427 V-8)

Diameter	.562
----------	------

REAR WHEEL ALIGNMENT

Curb	
Camber (degrees)	N1 to 0
Toe-in (total)	1/16 to 3/16

TORQUE CONTROL ARMS

Description	Welded steel box construction
-------------	-------------------------------

REAR SPRING

Type	Multi-leaf, 9 leaves
Material	Chrome carbon steel, heat treated
Length (developed) between eye centers	46.36
Width	2.25
Design load, lb @ -camber	1360 @ .352
Deflection rate, lb per inch, @ design load	
@ Spring	140
@ Wheel (wheel rate)	123
Spring liners	
Number	7
Location	Between all leaves except numbers 6 and 7
Material	Polyethylene with graphite

BRAKES

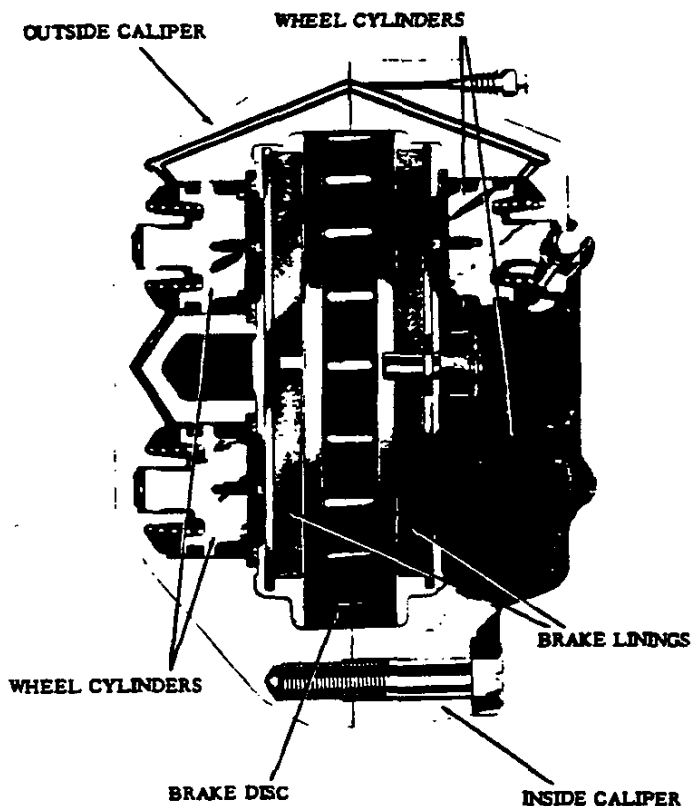

PARKING BRAKE

Type ----- Mechanical,
 internal (separate from rear service
 brakes); operates on rear wheels.
 Control ----- Floor mounted in central console
 Drum diameter ----- 6.5
 Brake lining
 Number ----- 2 shoes per each rear wheel
 Size (L x W x T) ----- 6.78 x 1.25 x .175
 Area (Sq. In.) ----- 33.9

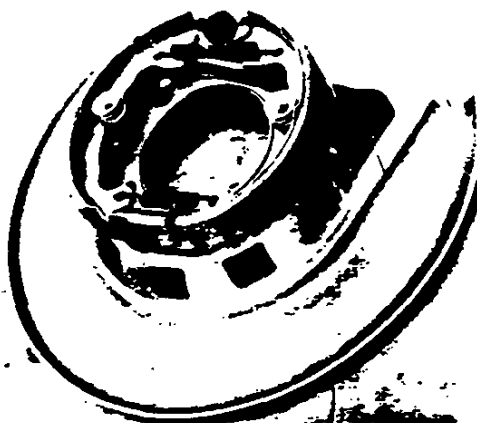

PARKING BRAKE

SERVICE BRAKES (Regular Production)

Type ----- Dual-circuit
 brake system with malfunction warning lamp
 and 4 wheel hydraulic caliper disc brakes
 Line pressure, psi, @ 100 lb pedal load ----- 576
 Braking ratios
 Pedal ----- 4.52
 Hydraulic ----- 43.3
 Overall ----- 196.0
 Distribution of braking effort ----- Front 65.0
 Brake disc
 Construction ----- Caliper type
 with radial cavities for heat dissipation
 Material ----- Cast iron
 Diameter, front & rear ----- 11.75
 Swept drum area (sq.in.) ----- 461.2
 Brake lining
 Material ----- Woven asbestos
 Size, all segments (L x W x T) ----- 5.96 x 2.21 x .41
 Method of attachment ----- Riveted
 Total effective area (sq.in.) ----- 78.1
 Gross lining area (sq.in.) ----- 86.3
 Master cylinder
 Piston diameter ----- 1.00
 Piston travel (with available pedal travel) ----- 1.10
 Wheel cylinders
 Number ----- 4 per wheel
 Piston diameter
 Front ----- 1.875
 Rear ----- 1.375
 Foot pedal travel ----- 5.00

POWER BRAKES, RPO J50

(Same as SERVICE BRAKES, Regular Production, except
 as follows)

General
 Type ----- Vacuum power unit
 added to assist master cylinder
 Braking ratios
 Pedal ----- 3.39
 Hydraulic ----- 43.3
 Overall ----- 147.0
 Master cylinder
 Piston travel (with foot pedal) ----- 1.20
 Foot pedal travel ----- 4.05

BULBS AND LAMPS

BULBS AND LAMPS	NUMBER REQUIRED AND TRADE NUMBER	CANDLE POWER PER LAMP
Air conditioning	2-1891	2
Back-up	2-1156	32
Cigarette lighter	1-1445	.7
Clock	2-1816	3
Courtesy		
Instrument panel	2-90	6
Rear compartment	1-90	6
Direction signal indicator	2-1816	3
Dome	1-90	6
Glove compartment	1-1893	2
Headlamp		
Outer	2-4002	High beam 37.5W Low beam 55.0W
Inner	2-4001	High beam 37.5W
Headlamp hi-beam indicator	1-1445	.7
Headlamp warning indicator	1-257	2
Heater	1-1893	2
Ignition switch	1-1445	.7
Instrument cluster	9-1816	3
License plate rear	1-67	4
Parking		
Park		4
Turn	2-1157	32
Parking brake alarm & warning light	1-257	2
Radio	1-1893	2
Spot lamp, portable	1-4416	30W
Tail		
Tail (only)	2-1156	32
Stop and turn		32
Tail	2-1157	4
Underhood	1-93	15

FUSES AND CIRCUIT BREAKERS

CIRCUIT	TYPE OF PROTECTION	LOCATION AND CIRCUIT*
Air conditioning	AGC 25 fuse	In line
Air conditioning lamp	AGC 25 fuse	Fuse panel (f)
Back-up lamps	AGC 4 fuse	Fuse panel (d)
Cigarette lighter	AGC 10 fuse	Fuse panel (b)
Cigarette lighter lamp	AGC 20 fuse	Fuse panel (c)
Clock	AGC 4 fuse	Fuse panel (d)
Clock lamps	AGC 20 fuse	Fuse panel (c)
Courtesy lamps	AGC 4 fuse	Fuse panel (d)
Direction signal flasher	AGC 20 fuse	Fuse panel (c)
Dome lamp	AGC 10 fuse	Fuse panel (b)
Fuel gage	AGC 20 fuse	Fuse panel (c)
Glove compartment lamp	15 amp CB	Light switch (g)
Headlamp hi-beam indicator lamp	40 amp CB	Hinge pillar (h)
Headlamp motors	40 amp CB	Hinge pillar (h)
Headlamp warning indicator lamp	15 amp CB	Light switch (g)
Headlamps	AGC 25 fuse	Fuse panel (f)
Heater	AGC 4 fuse	Fuse panel (d)
Heater lamp	AGC 4 fuse	Fuse panel (d)
Ignition switch lamp	AGC 4 fuse	Fuse panel (d)
Instrument cluster lamps	AGC 20 fuse	Fuse panel (c)
License plate, rear	AGC 10 fuse	Fuse panel (b)
Brake warning lamp	15 amp CB	Light switch (g)
Parking lamps	40 amp CB	Hinge pillar (h)
Power windows	AGC 20 fuse	Fuse panel (c)
Radio	AGC 4 fuse	Fuse panel (d)
Radio antenna	AGC 10 fuse	Fuse panel (b)
Radio lamp	AGC 20 fuse	Fuse panel (c)
Rear compartment vent motor	AGC 20 fuse	Fuse panel (c)
Speed warning device	AGC 20 fuse	Fuse panel (c)
Stop lamps	AGC 20 fuse	Fuse panel (c)
Tail lamps	AGC 20 fuse	Fuse panel (c)
Temperature gage	14 amp CB	Switch (j)
Windshield wiper	AGC 20 fuse	Fuse panel (c)
Spot lamp, portable		

* Letter suffix indicates same circuit



POWER TRAINS

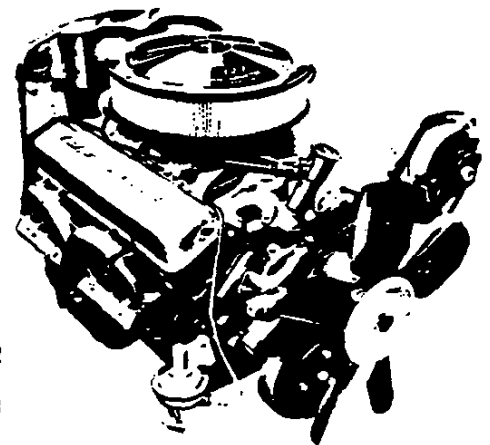
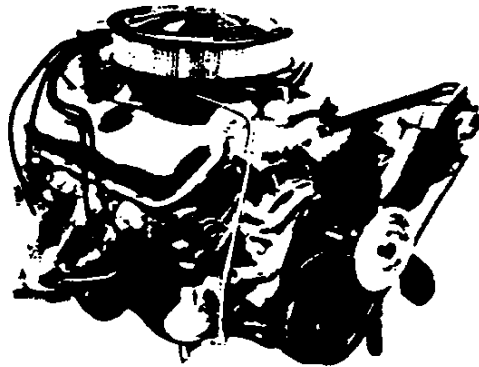

POWER TEAM COMBINATIONS	2
ENGINE DATA AND RATINGS	3
ENGINE SPEED AND PISTON TRAVEL	3
VEHICLE PERFORMANCE FACTORS	4
ENGINE OUTPUT CURVES	5
PRINCIPAL COMPONENTS	6
FUEL SYSTEM	11
EXHAUST AND VENTILATION SYSTEM	11
LUBRICATION SYSTEM	12
COOLING SYSTEM	13
ELECTRICAL SYSTEM	14
CLUTCHES	15
THREE AND FOUR SPEED TRANSMISSIONS	15
POWERGLIDE	16

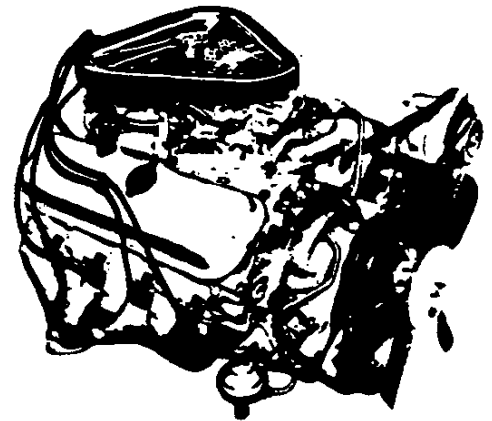

POWER TEAM COMBINATIONS

ENGINE	TRANSMISSION	MODEL APPLICATION	AXLE RATIOS				
			(Axle ratios for Air Conditioning same as base unless indicated otherwise)				
			3.08:1	3.36:1	3.55:1	3.70:1	4.11:1
327 Cubic Inch V-8 Turbo-Fire 327 300 HP Standard	3-Spd (2.54:1 low) & 4-Spd (2.52:1 low)	All Models	Econ.**	Std.*			
	Powerglide			Std.*			
327 Cubic Inch V-8 Turbo-Fire 327 350 HP RPO L79	4-Spd (2.52:1 low)	All Models		Std.*	Perf.**		
	4-Spd (2.20:1 low)					Std.*	Perf.**
427 Cubic Inch V-8 Turbo-Jet 427 390 HP RPO L36	4-Spd (2.52:1 low)	All Models	Std.**	Perf.**			
	4-Spd (2.20:1 low)		Econ.**	Std.**	Perf.**	Spcl.**	
	Powerglide	All Models	Econ.**	Std.**	Perf.**	Spcl.**	
		With Air Conditioning	Std.**				
427 Cubic Inch V-8 Turbo-Jet 427 400 HP RPO L68	4-Spd (2.52:1 low)	All Models	Std.**	Perf.**			
	4-Spd (2.20:1 low)		Econ.**	Std.**	Perf.**	Spcl.**	
	Powerglide	All Models	Econ.**	Std.**	Perf.**	Spcl.**	
		With Air Conditioning	Std.**				
427 Cubic Inch V-8 Turbo-Jet 427 435 HP RPO L71	4-Spd (2.20:1 low)	All Models (A)		Econ.**	Std.**	Perf.**	Spcl.**

(A) Air Conditioning not available.
 * Positraction axles available optionally.
 ** Available as positraction only.

Std. - Standard
 Econ. - Economy (optional)
 Perf. - Performance (optional)
 Spcl. - Special (optional)

MULTIPLICATION FACTORS

WITH MANUAL TRANSMISSIONS

ENGINE	CARBURETION	TRANSMISSION	TOTAL GEAR REDUCTION					AXLE RATIO
			1st	2nd	3rd	4th	Rev.	
300 HP Standard	4-Barrel	3-Speed (2.54:1)	8.53	5.04	3.36		8.84	3.36
		4-Speed (2.52:1)	8.47	6.32	4.94	3.36	8.70	
350 HP RPO L79	4-Barrel	4-Speed (2.52:1)	8.47	6.32	4.94	3.36	8.70	3.36
		4-Speed (2.20:1)	8.14	6.07	4.70	3.70	8.36	3.70
390 HP RPO L36	4-Barrel	4-Speed (2.52:1)	7.76	5.79	4.53	3.08	7.98	3.08
		4-Speed (2.20:1)	7.39	5.51	4.27	3.36	7.59	3.36
400 HP RPO L68	3x2 Barrel	4-Speed (2.52:1)	7.76	5.79	4.53	3.08	7.98	3.08
		4-Speed (2.20:1)	7.39	5.51	4.27	3.36	7.59	3.36
435 HP RPO L71	3x2 Barrel	4-Speed (2.20:1)	7.81	5.82	4.51	3.55	8.02	3.55

WITH AUTOMATIC TRANSMISSIONS

ENGINE	TRANSMISSION	SELECTOR POSITION	TOTAL TORQUE MULTIPLICATION*	AXLE RATIO
300 HP Standard 390 HP RPO L36 400 HP RPO L68	Powerglide	Drive	12.43:1 - 3.36:1	3.36:1
		Low & Reverse	12.43:1 - 5.91:1	

* Axle ratio x transmission ratio.

ENGINE DATA AND RATINGS

GENERAL DATA

Engine Type	V-8 OHV				
Piston Displacement (Cu. In.)	327		427		
Availability	Standard	RPO L79	RPO L36	RPO L68	RPO L71
Number of Cylinders	Eight				
Bore and Stroke (nominal)	4.00x3.25		4.251x3.76		
Compression Ratio	10.0:1	11.0:1	10.25:1	11.0:1	
Taxable (SAE) Horsepower	51.2		57.8		
Firing Order	1-8-4-3-6-5-7-2				
Idling Speed (RPM)	500	700	550	750	
Compression Press. (PSI @ Cranking Speed, Engine Hot)	160		160	170	
Lubrication	Full pressure				
Power Plant Mounting	Two front and one rear, compression type				
Measurements	Fan to rear of engine block		30.52	29.43	
	Top air cleaner to bottom oil pan		27.28	26.48	30.96
	Exhaust manifold to generator (width)		24.54	32.30	

ADVERTISED ENGINE RATING

Engine	327 Cu. In.		427 Cu. In.		
	300 HP	350 HP	390 HP	400 HP	435 HP
Availability	Standard	RPO L79	RPO L36	RPO L68	RPO L71
Gross Brake HP @ RPM	300 @ 5000	350 @ 5800	390 @ 5400	400 @ 5400	435 @ 5800
Gross Torque @ RPM (lb-ft)	360 @ 3400	360 @ 3600	460 @ 3600	460 @ 3600	460 @ 4000

ENGINE SPEED AND PISTON TRAVEL

Transmission	327 Cu. In.			427 Cu. In.					
	3-Speed (a)	4-Speed		Pr/Gld (a)	4-Speed			Pwr/Gld(f)	
Rear Axle Ratio	3.36:1	3.36:1	3.70:1 (b)	3.36:1	3.08:1 (c)	3.36:1 (d)	3.55:1 (e)	3.36:1	
Tire Size	7.75 x 15								
Crankshaft Revolutions per Mile	2550.2		2808.3	2553.6	2337.7	2550.2	2694.5	2550.2	
Crankshaft RPM @ MPH	Low	108.0	107.8	103.0	74.8	98.1	93.5	98.8	74.8
	Second	63.8	80.0	76.8		73.2	69.7	73.6	
	Third	42.5	62.5	59.4	42.5	57.3	53.9	57.0	42.5
	Fourth		42.5	46.8		39.0	42.5	44.9	
	Reverse	111.8	110.1	105.8	74.8	101.0	96.1	101.5	74.8
Piston Travel (Ft/Mile)	1381.4		1521.2	1381.4	1465.0	1598.2	1688.5	1465.0	

- (a) Available with 300 HP (Base) engine only
- (b) Standard ratio for 350 HP (L79) engine with 2.20:1 low transmission
- (c) Standard ratio for 390 HP (L36) & 400 HP (L68) engines with 2.52:1 low transmission
- (d) Standard ratio for 390 HP (L36) & 400 HP (L68) engines with 2.20:1 low transmission
- (e) Standard ratio for 435 HP (L71) engine with 2.20:1 low transmission
- (f) Available only with 390 HP (L36) & 400 HP (L68) engines

VEHICLE PERFORMANCE FACTORS

ENGINE	BASE 327 CU.IN. 300 HP	RPO L79 327 CU.IN. 350 HP	RPO L36 427 CU.IN. 390 HP	RPO L68 427 CU.IN. 400 HP	RPO L71 427 CU.IN. 435 HP
--------	------------------------------	---------------------------------	---------------------------------	---------------------------------	---------------------------------

3-SPEED TRANSMISSION

Performance Weight (pounds)	3456				
Pounds per Gross Horsepower	11.52				
Pounds per Cu.in. Displacement	10.57				
Gross HP per Cu.in. Displacement	.917				
Power Displacement (cu.ft./mile)	241.30				
Displacement Factor (cu.ft./ton mile)	139.64				

4-SPEED TRANSMISSION

Performance Weight (pounds)	3451	3451	3626	3626	3626
Pounds per Gross Horsepower	11.30	9.86	9.30	9.07	8.34
Pounds per Cu.in. Displacement	10.55	10.55	8.49	8.49	8.49
Gross HP per Cu.in. Displacement	.917	1.070	.913	.937	1.019
Power Displacement (cu.ft./mile)	241.30	241.30	288.83	288.83	332.91
Displacement Factor (cu.ft./ton mile)	139.88	139.88	159.31	159.31	183.62

POWERGLIDE*

Performance Weight (pounds)	3437		3632	3632	
Pounds per Gross Horsepower	11.52		9.31	9.08	
Pounds per Cu.in. Displacement	10.57		8.51	8.51	
Gross HP per Cu.in. Displacement	.917		.913	.937	
Power Displacement (cu.ft./mile)	241.30		315.09	315.09	
Displacement Factor (cu.ft./ton mile)	139.64		173.51	173.51	

* Data computed assuming zero slippage in torque converter.

GLOSSARY

Performance Weight	Curb Weight plus 300 Lb (weight of two 150 lb passengers)
Power Displacement	$\frac{\text{Crankshaft Revs/Mi} \times \text{Piston Displacement}}{2 \times 1728}$
Displacement Factor	$\frac{\text{Power Displacement}}{\text{Performance Wt (tons)}}$

ENGINE OUTPUT CURVES

ENGINE OUTPUT CURVES

TO BE

PROVIDED

PRINCIPAL COMPONENTS

CYLINDER BLOCK

Material	Cast alloy iron
Bore Diameter	
V8-327 Cu.In.	3.9995-4.0025
V8-427 Cu.In.	4.2495-4.2525
Bore Spacing (Centerline to Centerline)	
V8-327 Cu.In.	4.4
V8-427 Cu.In.	4.84
Number of Bulkheads	5
Water Jackets	Full length around each cylinder
Cylinder Numbering Arrangement (Front to Rear)	
Left Bank	1-3-5-7
Right Bank	2-4-6-8

CYLINDER HEAD

Material	High chrome cast alloy iron
Bolt Number	34 (327 Cu.In.); 32 (427 Cu.In.)
Bolt Size	.4375 dia.; 14 threads/inch

COMBUSTION CHAMBER VOLUME

(Total chamber volume of assembled engine with piston at top center)

V8-327 Cu.In. (Base)	4.69 Cu.In.
V8-327 Cu.In. (RPO L79)	4.17 Cu.In.
V8-427 Cu.In. (RPO L36 & L68)	5.90 Cu.In.
V8-427 Cu.In. (RPO L71)	4.92 Cu.In.

INLET MANIFOLD

Material	V8-327 Cu.In. (Base) & 427 (L36) --- Cast alloy iron
	V8-327 (RPO L79) & V8-427 Cu.In. (L68 & L71) --- Cast aluminum alloy
Heat Provision	Exhaust gas crossover at carburetor mounting pad

EXHAUST MANIFOLD

Material	Cast alloy iron
Type	
V8-327 Cu.In.	Dual, 4 port, exhaust emission to a single runner with center takedown collector
V8-427 Cu.In.	Dual, 4 port, extended runners from each port converging to a rear takedown collector
Outlet Diameter (Nominal)	2.50

CRANKSHAFT

Material	Forged steel
	Hardened journals on RPO L71
End Play	
V8-327 Cu.In.	.002-.006
V8-427 Cu.In.	.006-.010
Counter Weights	6
Crank Arm Length	
V8-327 Cu.In.	1.625
V8-427 Cu.In.	1.88
Torsional Damper	Rubber mounted inertia
Timing Gear	Steel; sprocket & chain
Pulley Pitch Diameter	6.64

CRANKSHAFTS AND BEARINGS 327 CUBIC INCH V-8 ENGINE

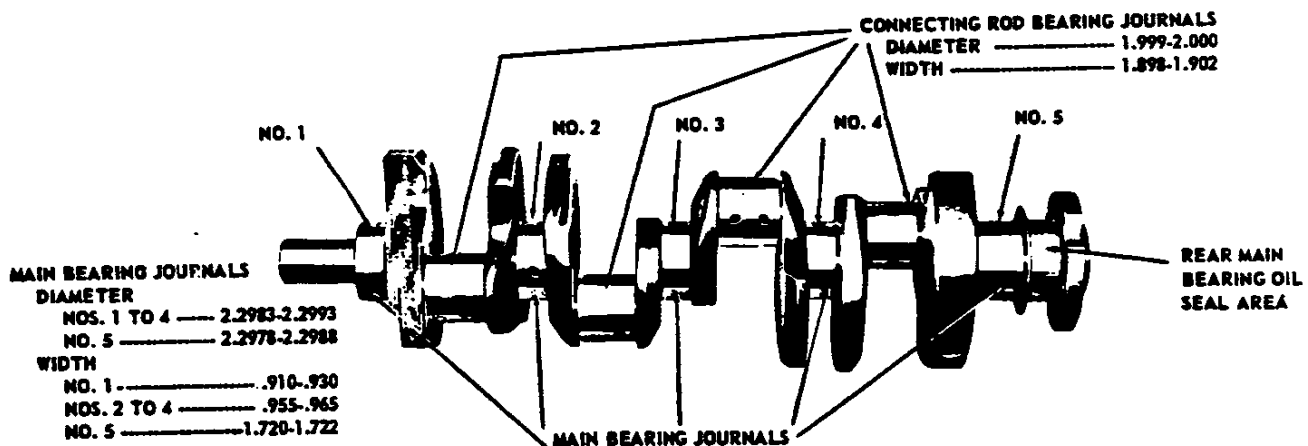

MAIN BEARINGS

Material ----- Premium aluminum except No. 5
 sintered copper nickel backed babbit
 Type ----- Precision removable
 Thrust Against Bearing No. ----- 5
 Clearance
 V8-327 Cu.In. ----- (#1) .0008-.0020;
 (#2, 3 & 4) .0008-.0024; (#5) .0015-.0031
 V8-427 Cu.In. (RPO L36 & L68) --- (#1 & 2) .0010-.0022;
 (#3 & 4) .0013-.0025; (#5) .0015-.0031
 V8-427 Cu.In. (RPO L71) ----- (#1-4) .0013-.0025;
 (#5) .0015-.0031

Dimensions	Theoretical Inner Dis.	Effective Length	Projected Area
V8-327 Cu.In.			
Bearing #1	2.3003	.752	1.7298
Bearing #2-4	2.3004	.752	1.7299
Bearing #5	2.3009	1.177	2.7081
V8-427 Cu.In. (RPO L36 & L68)			
Bearing #1-2	2.7507	.992	2.7287
Bearing #3-4	2.7505	.992	2.7285
Bearing #5	2.7506	1.2525	3.4451
V8-427 Cu.In. (RPO L71)			
Bearing #1-2	2.7510	.992	2.7290
Bearing #3-4	2.7505	.992	2.7285
Bearing #5	2.7506	1.2525	3.4451

CAMSHAFT

Material ----- Cast alloy iron
 Drive ----- Sprocket & chain; steel
 Lobe Lift
 V8-327 Cu.In. (Base) ----- .2600 Inlet; .2733 Exhaust
 V8-327 Cu.In. (RPO L79) ----- .2981 Inlet & Exhaust
 V8-427 Cu.In. (RPO L36 & L68) ----- .2714 Inlet;
 .2624 Exhaust
 V8-427 Cu.In. (RPO L71) ----- .3057 Inlet & Exhaust
 Bearings ----- 5; steel backed babbit

VALVE TRAIN

Type ----- Individually mounted
 overhead rocker arms, push rod actuated
 Lifters ----- Hydraulic
 V8-427 Cu.In. (RPO L71) - Mechanical
 Push Rods
 Type ----- Hollow steel
 Ends
 V8-327 (Base) & 427 Cu.In. ----- Hardened
 V8-327 Cu.In. (RPO L79) ----- Hardened steel
 insert on rocker arm ends
 Rocker Arms
 Material ----- Stamped steel
 Ratio
 V8-327 Cu.In. ----- 1.50:1
 V8-427 Cu.In. ----- 1.70:1

VALVE SPRINGS

Diameter (I.D.)
 V8-327 Cu.In. ----- .868-.884
 V8-427 Cu.In. ----- 1.082-1.098
 Installed Length (In. @ Lb.)
 Valves Closed
 V8-327 Cu.In. ----- 1.70 @ 76-84
 V8-427 Cu.In. ----- 1.88 @ 94-106
 Valves Opened
 V8-327 Cu.In. ----- 1.25 @ 180-192
 V8-427 Cu.In. ----- 1.38 @ 303-327
 Free Length
 V8-327 Cu.In. ----- 2.03
 V8-427 Cu.In. ----- 2.09
 Valve Spring Damper
 V8-327 Cu.In. ----- Flat steel, 4 coils
 V8-427 Cu.In. ----- Flat steel, 3.62 coils

**CAMSHAFT AND BEARINGS
 327 CUBIC INCH V-8 ENGINE**

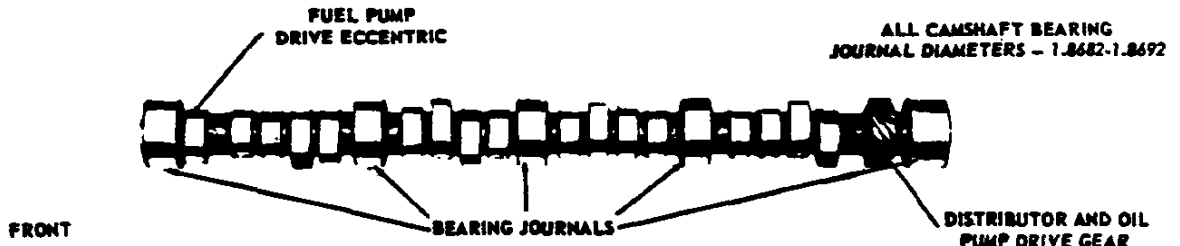

PRINCIPAL COMPONENTS—Cont'd.

VALVES - INLET

Material	Alloy steel
Coating	
V8-327 Cu.In.	None
V8-427 Cu.In.	Face & head aluminized
V8-327 (RPO L79) & 427 (RPO L71)	Chrome flash stem
Valve Guide Inserts (V8-427)	Cast alloy iron

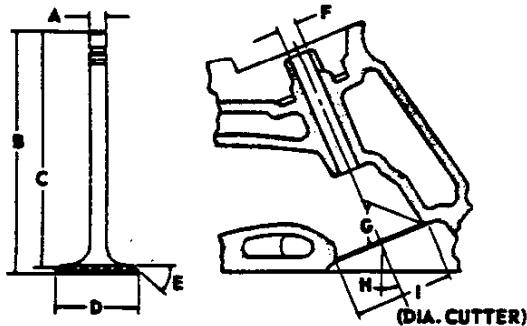

A - Stem Diameter	
V8-327 Cu.In.	.3410-.3417
V8-427 Cu.In.	.3715-.3722
B - Overall Length	
V8-327 Cu.In.	4.870-4.889
V8-427 Cu.In. (RPO L36 & L68)	5.215-5.235
V8-427 Cu.In. (RPO L71)	5.204-5.224
C - Gage Length	
V8-327 Cu.In.	4.785-4.795
V8-427 Cu.In.	5.115-5.125
D - Overall Head Diameter	
V8-327 Cu.In. (Base)	1.935-1.945
V8-327 Cu.In. (RPO L79)	2.017-2.023
V8-427 Cu.In. (RPO L36 & L68)	2.060-2.070
V8-427 Cu.In. (RPO L72)	2.185-2.195
E - Angle of Face	45°
F - Guide Diameter	
V8-327 Cu.In.	.3427-.3437
V8-427 Cu.In.	.3732-.3742
G - Angle of Seat	46°
H - Valve Angle	
V8-327 Cu.In.	23°
V8-427 Cu.In.	4°
I - Valve Seat (Cutter) Diameter	
V8-327 Cu.In. (Base)	1.990-2.010
V8-327 Cu.In. (RPO L79)	2.020
V8-427 Cu.In.	2.150

VALVES - EXHAUST

Material	High alloy steel
Coating	
V8-327 Cu.In.	Aluminum face
V8-427 Cu.In.	Face & head aluminized
V8-327 (RPO L79) & 427 (RPO L71)	Cu.In. --- Chrome flash stem
Valve Guide Inserts (V8-427)	Cast alloy iron

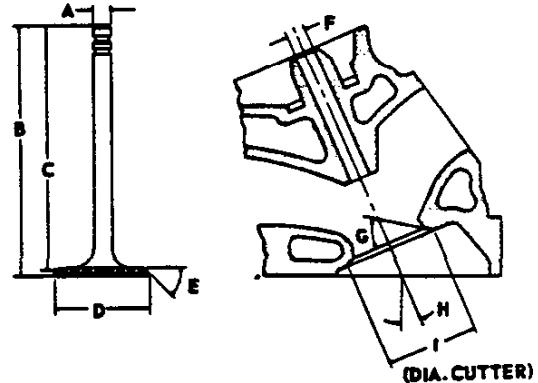

A - Stem Diameter	
V8-327 Cu.In.	.3410-.3417
V8-427 Cu.In.	.3713-.3720
B - Overall Length	
V8-327 Cu.In. (Base)	4.913-4.933
V8-327 Cu.In. (RPO L79)	4.891-4.910
V8-427 Cu.In.	5.345-5.365
C - Gage Length	
V8-327 Cu.In.	4.781-4.791
V8-427 Cu.In.	5.235-5.245
D - Overall Head Diameter	
V8-327 Cu.In. (Base)	1.495-1.505
V8-327 Cu.In. (RPO L79)	1.595-1.605
V8-427 Cu.In.	1.715-1.725
E - Angle of Face	45°
F - Guide Diameter	
V8-327 Cu.In.	.3427-.3437
V8-427 Cu.In.	.3732-.3742
G - Angle of Seat	46°
H - Valve Angle	
V8-327 Cu.In.	23°
V8-427 Cu.In.	4°
I - Valve Seat (Cutter) Diameter	
V8-327 Cu.In. (Base)	1.550-1.570
V8-327 Cu.In. (RPO L79)	1.600
V8-427 Cu.In.	1.625

PISTONS

Material

V8-327 Cu.In. (Base) ----- Cast aluminum alloy
 V8-327 Cu.In. (RPO L79) -- Aluminum impact extruded
 V8-427 Cu.In. (RPO L36 & L68) -- Cast aluminum alloy
 V8-427 Cu.In. (RPO L71) -- Aluminum impact extruded

Head Type

V8-327 Cu.In. (Base) ----- Flat, notched
 V8-327 Cu.In. (RPO L79) ----- Domed
 V8-427 Cu.In. ----- Domed

Skirt Type

----- Slipper

Top Land Clearance

V8-327 Cu.In. (Base) ----- .0365-.0455
 V8-327 Cu.In. (RPO L79) ----- .0395-.0425
 V8-427 Cu.In. (RPO L36 & L68) ----- .0305-.0375
 V8-427 Cu.In. (RPO L71) ----- .0265-.0335

Skirt Clearance

V8-327 Cu.In. (Base) ----- .0005-.0011
 V8-327 Cu.In. (RPO L79) ----- .0024-.0030
 V8-427 Cu.In. (RPO L36 & L68) ----- .0009-.0015
 V8-427 Cu.In. (RPO L71) ----- .0040-.0046

Compression Ring Groove Depth

V8-327 Cu.In. ----- .2217-.2283
 V8-427 Cu.In. ----- .2348-.2413

Oil Ring Groove Depth

V8-327 Cu.In. ----- .2038-.2103
 V8-427 Cu.In. (RPO L36 & L68) ----- .2183-.2248
 V8-427 Cu.In. (RPO L71) ----- .2133-.2148

Pin Bore Offset

V8-327 (Base) & 427 (RPO L36 & L68) ----- .055-.065
 V8-327 (RPO L79) & 427 (RPO L71) ----- On center

Compression Height

V8-327 Cu.In. (Base) ----- 1.674-1.676
 V8-327 Cu.In. (RPO L79) ----- 1.673-1.677
 V8-427 Cu.In. (RPO L36 & L68) ----- 1.908-1.912
 V8-427 Cu.In. (RPO L71) ----- 1.768-1.772

PISTON PINS

Material ----- Chromium steel

Length

V8-327 Cu.In. ----- 2.990-3.010
 V8-427 Cu.In. ----- 2.930-2.950

Diameter

V8-327 Cu.In. ----- .9270-.9273
 V8-427 Cu.In. ----- .9895-.9898

Clearance in Piston

V8-327 Cu.In. (Base) ----- .00015-.00025
 V8-327 Cu.In. (RPO L79) ----- .00045-.00055
 V8-427 Cu.In. (RPO L36 & L68) ----- .00025-.00035
 V8-427 Cu.In. (RPO L71) ----- .00030-.00040

Pin Mounting ----- Locked in rod by shrink fit

VALVE LIFT

V8-327 Cu.In. (Base) ----- .3900 Inlet & .4100 Exhaust
 V8-327 Cu.In. (RPO L79) ----- .4472 Inlet & Exhaust
 V8-427 Cu.In. (RPO L36 & L68) ----- .4614 Inlet;
 .4800 Exhaust
 V8-427 Cu.In. (RPO L71) ----- .5197 Inlet & Exhaust

VALVE TIMING (Crankshaft Degrees)

V8-327 Cu.In. - Base	Excluding Ramps	Including Ramps
Inlet Valve (Zero lash)		
Opens - BTC	28°	38°
Closes - ABC	72°	92°
Duration	280°	310°
Exhaust Valve (Zero lash)		
Opens - BBC	78°	88°
Closes - ATC	30°	52°
Duration	288°	320°

V8-327 Cu.In. - RPO L79	Excluding Ramps	Including Ramps
Inlet Valve (Zero lash)		
Opens - BTC	40°	54°
Closes - ABC	86°	108°
Duration	306°	342°
Exhaust Valve (Zero lash)		
Opens - BBC	88°	102°
Closes - ATC	38°	60°
Duration	306°	342°

V8-427 Cu.In. - RPO L36 & L68	Excluding Ramps	Including Ramps
Inlet Valve (Zero lash)		
Opens - BTC	40°	56°
Closes - ABC	80°	114°
Duration	300°	350°
Exhaust Valve (Zero lash)		
Opens - BBC	88°	110°
Closes - ATC	32°	62°
Duration	300°	352°

V8-427 Cu.In. - RPO L71	Excluding Ramps	Including Ramps
Inlet Valve (opens with .024 lash)		
Opens - BTC		44°
Closes - ABC		92°
Duration		316°
Exhaust Valve (closes with .028 lash)		
Opens - BBC		86°
Closes - ATC		36°
Duration		302°

PRINCIPAL COMPONENTS—Cont'd.

COMPRESSION RING - UPPER

Material	-----	Cast alloy iron
Type	-----	Inside bevel (bottom of ring 30 degrees to piston vertical axis) No bevel on V8-327 (L79) & V8-427
Face		
V8-327 Cu.In. (Base)	-----	Tapered edge
V8-327 Cu.In. (RPO L79)	-----	Straight edge
V8-427 Cu.In.	-----	Barrel edge
Coating		
V8-327 Cu.In. (Base)	-----	Chrome plate
V8-327 Cu.In. (RPO L79)	-----	Molybdenum inlay
V8-427 Cu.In.	-----	Molybdenum inlay
Width		
V8-327 Cu.In. (Base)	-----	.0775-.0780
V8-327 Cu.In. (RPO L79)	-----	.0770-.0775
V8-427 Cu.In.	-----	.0770-.0775
Wall Thickness		
V8-327 Cu.In.	-----	.190-.200
V8-427 Cu.In.	-----	.202-.212
Gap		
V8-327 Cu.In. (Base)	-----	.013-.023
V8-327 Cu.In. (RPO L79)	-----	.010-.020
V8-427 Cu.In.	-----	.010-.020

COMPRESSION RINGS - LOWER

Material	-----	Cast alloy iron
Type	-----	Inside bevel (top of ring 50 degrees to piston vertical axis V8-327 Base, 30 degrees RPO L79 & 28-52 degrees for V8-427)
Face	-----	Tapered
Coating		
V8-327 Cu.In. (Base)	-----	Wear resistant
V8-327 Cu.In. (RPO L79)	-----	Chrome plate
V8-427 Cu.In. (RPO L36 & L68)	-----	Wear resistant
V8-427 Cu.In. (RPO L71)	-----	Chrome plate
Width		
V8-327 Cu.In. (Base)	-----	.0770-.0775
V8-327 Cu.In. (RPO L79)	-----	.0775-.0780
V8-427 Cu.In.	-----	.0770-.0775
Wall Thickness		
V8-327 Cu.In. (Base)	-----	.164-.170
V8-327 Cu.In. (RPO L79)	-----	.190-.200
V8-427 Cu.In.	-----	.202-.212
Gap		
V8-327 Cu.In. (Base)	-----	.013-.023
V8-327 Cu.In. (RPO L79)	-----	.013-.023
V8-427 Cu.In.	-----	.010-.020
Expander (Used with V8-327 Cu.In. Base Only)		
Material	-----	Steel
Width	-----	.068-.074
Wall Thickness	-----	.0180

OIL CONTROL RINGS

Type	-----	Multi-piece (two rails and one spacer)
Material		
Rails	-----	Steel
Spacer	-----	Alloy steel
Width (assembled)		
V8-327 Cu.In.	-----	.1870-.1890
V8-427 Cu.In.	-----	.1870-.1890
Wall Thickness		
V8-327 Cu.In.	-----	.150-.156
V8-427 Cu.In.	-----	.137-.143
Gap		
V8-327 Cu.In.	-----	.015-.055
V8-427 Cu.In.	-----	.010-.030
Rail Coatings	-----	Chrome plated

CONNECTING RODS

Material	-----	Drop forged steel
V8-427 (RPO L72)	-----	High alloy steel
Length (center to center)		
V8-327 Cu.In.	-----	5.699-5.701
V8-427 Cu.In.	-----	6.130-6.140

CONNECTING ROD BEARINGS

Material	-----	Premium aluminum
Type	-----	Precision removable
Clearance		
V8-327 Cu.In.	-----	.0007-.0027
V8-427 Cu.In. (RPO L36 & L68)	-----	.0009-.0029
V8-427 Cu.In. (RPO L71)	-----	.0014-.0034
Theoretical I.D.		
V8-327 Cu.In.	-----	2.0017
V8-427 Cu.In. (RPO L36 & L68)	-----	2.2014
V8-427 Cu.In. (RPO L71)	-----	2.2019
Effective Length		
V8-327 Cu.In.	-----	.807
V8-427 Cu.In.	-----	.857
End Play		
V8-327 Cu.In.	-----	.009-.013
V8-427 Cu.In.	-----	.016-.020

FUEL—EXHAUST AND VENTILATION SYSTEM

FUEL SYSTEM

FUEL TANK

Capacity (Gal) ----- 20 (approximately)
 Location ----- In body cavity at rear of deck area
 Filler Location ----- Center of rear deck lid

FUEL FILTERS, DUAL

In Fuel Tank ----- Mesh strainer
 Carburetor Inlet ----- Sintered bronze filter

FUEL PUMP

Type ----- Diaphragm
 Drive ----- Camshaft eccentric
 Location ----- Lower right front of engine
 Pressure Range
 V8-327 Cu.In. ----- 5.25-6.50 PSI
 V8-427 Cu.In. ----- 5.00-6.50 PSI

AIR CLEANER

Type
 V8-327 & 427 (RPO L36) ----- Full circle inside,
 chrome plated
 V8-427 (RPO L68 & L71) ----- Triangular shaped,
 chrome plated
 Diameter ----- 16.78
 Filter Element ----- Oil-waxed paper
 V8-427 (RPO L68 & 71) ----- Polyurethane

CARBURETORS

Make & Type
 V8-327 Cu.In. ----- Holley, 4-barrel, downdraft
 V8-427 Cu.In. (RPO L36) ----- Holley,
 4-barrel, downdraft
 V8-427 Cu.In. (RPO L68 & L71) ----- Holley,
 3x2, downdraft
 SAE Flange Size ----- 1.50
 Throttle Bore
 V8-327 Cu.In. ----- 1.561 Primary & Secondary
 V8-427 Cu.In. (RPO L36) ----- 1.561 Primary
 & Secondary
 V8-427 Cu.In. (RPO L68 & L71) ----- 1.50 No. 1
 Primary, 1.75 No. 2 & 3 Secondary
 Venturi Diameter
 V8-327 Cu.In. ----- 1.25 Primary
 1.4375 Secondary
 V8-427 Cu.In. (RPO L36) ----- 1.25 Primary
 1.3125 Secondary
 V8-427 Cu.In. (RPO L68 & L71) ----- 1.1875 No. 1
 Primary, 1.375 No. 2 & 3 Secondary
 Secondary Throttle Actuation ----- By linkage
 approximately when primary valves are
 opened half between closed and open

CHOKE

Type ----- Automatic

EXHAUST AND VENTILATION SYSTEM

EXHAUST SYSTEM

Type ----- Dual with no resonators

MUFFLERS

Type ----- Dual, reverse flow
 Construction ----- Heads and body joined
 by rolled lock seam construction
 Shell
 Right Hand ----- .036 stainless steel
 Left Hand ----- .036 sheet steel aluminum coating
 Wrap ----- .030 indented asbestos sheet
 Cover ----- .018 sheet steel aluminum coating
 Heads
 Right Hand ----- .048 stainless steel
 Left Hand ----- .048 sheet steel aluminum coating
 Baffles
 Right Hand ----- 4; #1 & #4, .036 stainless steel;
 #2 & #3, .036 sheet steel aluminum coating
 Left Hand ----- 4; .036 sheet steel aluminum coating
 Length, Body ----- 17.00
 Width (I.D.) ----- 9.25
 Height (I.D.) ----- 5.00

EXHAUST PIPES

Type ----- Two piece; front and rear assemblies
 Material ----- Seamless steel tubing
 Dimensions (O.D.) ----- 2.50 (2.00 on 327 P/Gld)
 Wall Thickness
 Front Pipes ----- .067-.081 (327); .072-.092 (427)
 Rear Pipes ----- .084-.104 laminated
 .067-.081 (327 Powerglide)

TAIL PIPES

Material ----- Stainless steel
 Dimensions (O.D.) ----- 2.00
 Wall Thickness ----- .023

ENGINE VENTILATION

Type ----- Closed-positive;
 fumes withdrawn into induction system
 from crankcase via hoses connecting to oil
 filler tube and fitting at base of carburetor.

AIR INJECTION REACTOR (California vehicles only)

Type ----- Air injected
 into exhaust ports by crankshaft driven pump

LUBRICATION SYSTEM

GENERAL

Type ----- Controlled full pressure
 Main Bearings ----- Pressure
 Connecting Rods ----- Pressure
 Piston Pins ----- Splash
 Cylinder Walls ----- Pressure, jet cross sprayed
 Camshaft Bearings ----- Pressure
 Valve Lifters ----- Pressure
 Rocker Arms ----- Pressure
 Timing Gears ----- Centrifugally oiled from front camshaft bearing

Oil Pressure Sending Unit

Type ----- Bourdon tube
 Actuation ----- Oil pressure

Oil Filler

Cap ----- Positive seal
 Location
 V8-327 Cu.In. ----- Left front of intake manifold
 V8-427 Cu.In. --- Top center of right rocker cover

OIL PUMP

Type ----- Gear
 Normal Oil Pressure (No Flow Conditions)
 V8-327 Cu.In. ----- 30-45 PSI @ 1500 RPM
 V8-427 Cu.In. ----- 50-75 PSI @ 2000 RPM
 Intake Type ----- Fixed
 Capacity (GPM @ Eng. RPM)
 V8-327 Cu.In. ----- 4.3 @ 2000
 V8-427 Cu.In. ----- 6 @ 2000
 Regulator Valve ----- Opens between 40-45 lbs

OIL DIP STICK - LOCATION

V8-327 Cu.In. ----- Right side, rear of engine block
 V8-427 Cu.In. ----- Right side, center, direct to oil pan

CRANKCASE CAPACITY (Quarts)

Refill
 V8-327 Cu.In. (Base) ----- 4.0
 V8-327 Cu.In. (RPO L79) ----- 5.0
 V8-427 Cu.In. ----- 5.0
 Refill with Filter Change
 V8-327 Cu.In. (Base) ----- 5.0
 V8-327 Cu.In. (RPO L79) ----- 6.0
 V8-427 Cu.In. ----- 6.0

OIL FILTER

Type ----- Full flow, replaceable element
 Location ----- Left rear underside of engine
 Capacity ----- One quart
 By-pass Valve ----- Opens between 9 to 11 PSI drop in pressure

LUBRICANT GRADES AND TEMPERATURES

32° F and Above ----- SAE 20W, SAE 20 or SAE 10W-30
 0° F and Above ----- SAE 10W or SAE 10W-30
 Below 0° F ----- SAE 5W or SAE 5W-20
 Alternate ----- SAE 5W-30 can be used for 5W;
 5W-20 or 10W-30

OIL PAN

Type of Drain Plug ----- Hex head
 Location ----- Lower rear edge of oil pan sump
 Size Hex Head ----- .860-.875
 Thread ----- 1/2-20 UNF 2A
 Length ----- .081
 Diameter ----- .410-.430

COOLING SYSTEM

GENERAL

Type	Liquid, pressurized
V8-327 Cu.in. (Base)	Internal by-pass
V8-327 Cu.in. (RPO L79)	External by-pass
V8-427 Cu.in.	External by-pass
Capacity (with Heater)	
V8-327 Cu.in.	16 Qts
V8-427 Cu.in.	23 Qts

RADIATOR

Type	
V8-327 Cu.in.	Aluminum, cross-flow
V8-427 Cu.in.	Copper-brass, cross-flow
Core Constant and Thickness	
Distance between Fins	
V8-327 Cu.in.	.18
V8-427 Cu.in.	.16
Distance between Tubes	.55
Thickness of Core	
V8-327 Cu.in.	2.88
V8-427 Cu.in.	2.70
Frontal Area (Sq. In.)	
V8-327 Cu.in.	315
V8-427 Cu.in.	382

SURGE TANK (327 Cu.in. Only)

Location	Right side engine compartment connected by hose to top of radiator
Capacity	2.3 Qts
Fill Requirements	Half full when weather is cold

RADIATOR CAP RELIEF VALVE

Opens at	Approximately 15 PSI
----------	----------------------

FAN

Number of Blades	5, staggered
Diameter	
V8-327 Cu.in.	17.12
V8-427 Cu.in.	17.50
Fan Pulley Pitch Diameter	7.00
Drive	
Type	Thermomodulated fluid coupling
Performance at 4000 RPM input	At 135°-155°F fan speed 3200 to 3500 RPM; at 120°F and below, fan speed 800-1800 RPM

THERMOSTAT

Type	Pellet
Begins to Open at	177°-182°F
Fully Opened at	221°F

RADIATOR HOSE

Outlet, Lower (Radiator to Water Pump)	
V8-327 Cu.in.	1.75 I.D.
V8-427 Cu.in.	1.88 I.D.
Inlet, Upper (Thermostat Housing to Radiator)	
V8-327 Cu.in.	1.56 I.D.
V8-427 Cu.in.	1.50 I.D.

BY-PASS THERMOSTAT HOSE

V8-327 Cu.in. (RPO L79)	.725-.765 I.D.
V8-427 Cu.in.	.725-.765 I.D.

BELTS; CRANKSHAFT, FAN AND GENERATOR

Number Used	
V8-327 Cu.in. (Base)	One
V8-327 Cu.in. (RPO L79)	Two
V8-427 Cu.in.	Two
Angle of "V"	38°-42°
Pitch Line	
Fan, Generator and Water Pump Belt	
V8-327 Cu.in. (Base)	53.25
V8-327 Cu.in. (RPO L79)	54.00
V8-427 Cu.in.	56.00
Fan and Water Pump Belt	
V8-327 Cu.in. (RPO L79)	34.40
V8-427 Cu.in.	34.40
Width	.380

WATER PUMP

Type	Centrifugal
Capacity (GPM @ Engine RPM)	
V8-327 Cu.in.	57 @ 4400
V8-427 Cu.in.	82 @ 5200
Bearing	Permanently lubricated double row ball
Drive	Fan belt
Ratio (Pump to Engine RPM)	.949:1

DRAIN LOCATIONS AND TYPE

Radiator	Percock, left side at bottom
Engine Block	Plug; right and left center

ELECTRICAL SYSTEM

SUPPLY SYSTEM

BATTERY

Voltage ----- 12
 Capacity (SAE) ----- 61 amp hr @ 20 hr rate
 Total Number of Plates ----- 66
 Number of Cells ----- 6
 Terminal Grounded ----- Negative
 Location ----- Rear of left wheelhouse

GENERATOR

Type ----- Diode rectified
 Rating -----
 Amps ----- 9-37
 Volts ----- 10-15
 Drive ----- By fan belt
 Pulley Pitch Diameter ----- 2.70
 Ratio (Gen to Engine Speed) ----- 2.46:1

REGULATOR

Type ----- Two unit; vibrator
 Voltage Regulator -----
 Voltage ----- 13.8-14.8 @ 85 °F
 Field Relay (Combination Light & Field Relay)
 Closing Voltage ----- 1-3 Volts @ 80 °F
 Location ----- Right side front engine compartment

STARTING SYSTEM

STARTING MOTOR

Rotation (Drive End View) ----- Clockwise
 Test Conditions --- Engine at operating temperature
 No Load Test -----
 Amps ----- 65-100 (327); 70-99 (427)
 Volts ----- 10.6
 RPM ----- 3600-5100 (327); 7800-12000 (427)

Motor Drive

Engagement ----- Solenoid
 Pinion Meshes at ----- Rear
 Pinion Tooth No. ----- 9
 Flywheel Tooth No. ----- 153; V8-427 -- 168
 Mounting ----- Bolted to clutch housing

IGNITION SYSTEM

DISTRIBUTORS ----- Refer to chart below

IGNITION PULSE AMPLIFIER

(Used with RPO L71 Transistor Ignition System)

COIL

Type ----- 12 Volt
 Amperes Drawn -----
 Engine Stopped ----- 4.0
 Engine Idling ----- 1.8

SPARK PLUGS

Make & Type -----
 V8-327 Cu.In. ----- AC44
 V8-427 Cu.In. ----- AC43N
 Thread Size (mm) ----- 14
 Gap ----- .033-.038
 Torque ----- 25 lb ft

CABLE

----- Linen core impregnated
 with electrical conducting material and
 insulation of rubber with neoprene jacket

DISTRIBUTORS	V-8 327 Cu.In. Base 300 HP	V-8 327 Cu.In. RPO L79 350 HP	V-8 427 Cu.In. RPO L36 390 HP	V-8 427 Cu.In. RPO L68 400 HP	V-8 427 Cu.In. RPO L71 435 HP
Make	Delco-Remy				
Model	1111194	1111196	1111247	1111258	
Type	Single Breaker				
Cam Angle	28°-32°				
Breaker Gap	.019 (new)				
Breaker Arm Tension	19-23 oz				
Centrifugal Advance Begins (RPM)	900				
Max Degrees @ RPM	30 @ 5100		32 @ 5000		30 @ 3800
Vacuum Advance Begins (In. Hg)	6	4	7		8
Max Degrees @ In. Hg	15 @ 12	16 @ 7	12 @ 12		15 @ 15.5
Timing (Initial Design Setting) Crankshaft Degrees @ RPM (with vacuum spark line disconnected)	6° BTDC @ 500	10° BTDC @ 700	4° BTDC @ 550		5° BTDC @ 750
Timing Mark Location	Torsional Damper				

CLUTCHES AND TRANSMISSIONS

CLUTCHES

Engine	Type	V-8 327 Cubic Inch		V-8 427 Cubic Inch		
	Availability	Regular Production	RPO L79	RPO L36 & L68	RPO L72	
Clutch for		3-Speed & 4-Speed	4-Speed	4-Speed		
Type		Single dry disc, centrifugal				
Clutch cover & pressure plate	Eff. plate load, lbs.	2100-2300		2450-2750	2500-2800	
	Press. plate matl.	Nodular iron				
	Clutch spring type	Circular plate diaphragm, bent finger design				
	Clutch spring matl.	Heat treated spring steel				
Driven plate	Type	Single disc with two friction surfaces				
	Cushions	Flat spring steel between friction rings				
	Dampers	10 coil springs (5 sets of two)				
	Friction rings	OD	11.00			
		ID	6.50			
	Total area sq.in.	123.70				
	Material	Woven type asbestos				
Material	Heat treated HR steel					
Flywheel	Ring gear	No. of teeth	133	168		
		PD	12.75	14.00		
	Attachment	Shrink fit				
Bearings	Release	Type	Single row ball			
		Lubrication	None, prepacked			
	Pilot	Type	Bronze bushing			
		Lubrication	None, sintered and oil impregnated			
Controls	Clutch fork	Drop forged steel, pivot mounted on ball				
	Pedal mounting	Pendant, from brace on dash				
	Lubrication	Crossover shaft				
Clutch housing material		Aluminum alloy				

3-SPEED AND 4-SPEED TRANSMISSIONS

Transmission Type		3-Speed	4-Speed RPO M20		4-Speed RPO M21		
Engine	Type	V8-327 Cu.In.	V8-327 Cu.In.	V8-427 Cu.In.	V8-327 Cu.In.	V8-427 Cu.In.	
Application	Availability	Standard	Standard	RPO L79	L36 & L68	RPO L79 L36, L68 & L71	
Case material		Cast iron	Aluminum				
Gear Shift	Type	Remote					
	Control	Lever					
	Location	Floor, mounted between seats					
Gears	Type	Helical					
	Material	Forged steel, hardened					
	Synchronization	All forward gears					
	Constant mesh gear	All gears	All forward gears				
	Sliding gears	None	Reverse				
	Ratios	First	2.54	2.52			2.20
		Second	1.50	1.88			1.64
		Third	1.00	1.47			1.27
		Fourth		1.00			1.00
Reverse		2.63	2.59			2.26	
Lubricant	Type	Meeting Military Specification MIL-L-2105-B					
Capacity (pts)		3					
Extension	Material	Cast iron	Aluminum				
	Oil seal	Steel encased double seal of spring loaded rubber or felt					

TRANSMISSIONS - Cont'd.

GENERAL

Type ----- Automatic hydraulic torque converter
with planetary gear system for low and reverse

Selector lever ----- Floor

Location ----- Floor

Operation ----- Actuates manual valve
in hydraulic control system

Selector positions ----- P-R-N-D-L

Parking brake ----- Positive

Type ----- Positive

Operation ----- Applied by selector lever
through spring-loaded linkage

Method of cooling ----- Air heat exchanger

Flywheel assembly ----- Steel stamping with
welded on ring gear

HYDRAULIC CONTROLS

Manual valve type ----- Spool

Pressure regulator valve type ----- Spool

Pressure range, psi @ idle
(Conditions: 450 RPM input, 25 inches Hg vacuum)

Drive -----

Minimum ----- 48

Maximum ----- 54

Low -----

Minimum ----- 124

Maximum ----- 139

Reverse -----

Minimum ----- 80

Maximum ----- 90

CONVERTER ASSEMBLY

Type ----- Three element

Pump -----

Description ----- Sheet steel shells and
vanes; welded to converter housing

Turbine -----

Description ----- Sheet steel
shells and vanes, supported in converter cover;
operation independent of cover and pump housing

Stator -----

Description ----- Aluminum
air foil supported on a stationary sleeve by an
over-running clutch of cam and roller design

Stall torque ratio ----- 2.10:1

Stall speed (RPM) -----

V8-327 (Base) ----- 1730

V8-427 (RPO L36 & L48) ----- 2220

Diameter (nominal) ----- 11.75

PLANETARY GEAR SET

Type ----- Compound planetary

Range -----

Drive ----- 1.76:1 to 1:1

Low ----- 1.76:1

Reverse ----- 1.76:1

Low band ----- Three linked circular segments

Low band servo ----- Piston with
release spring and inner cushion spring

CASE

Material ----- (One piece) aluminum

OUTPUT SHAFT RPM (VEHICLE SPEED MPH)

N/V factor -----	42.9	
Upshift -----	V8-327	V8-427
Closed throttle	660(16)	661(15)
Throttle at detent	2340(55)	2632(61)
Full detent	2742(64)	3085(72)
Downshift -----		
Closed throttle	614(14)	614(14)
Throttle at detent	882(21)	945(22)
Full detent	2584(60)	2905(68)

HIGH CLUTCH

Type ----- Multi-disk

Drive plates -----

Description ----- Waved steel
with bonded organic facings

Number ----- 4

Driven plates -----

Description ----- Flat steel

Number ----- 5

REVERSE CLUTCH

Type ----- Multi-disk

Drive plates -----

Description ----- Flat steel with
bonded organic facings

Number ----- 327 Cu. In. 5; 427 Cu. In. 6

Driven plates -----

Description ----- Flat steel

Number ----- 327 Cu. In. 5; 427 Cu. In. 6

TORQUE MULTIPLICATION

Maximum overall ratio ----- 3.70:1

Low and reverse ----- 3.70:1 to 1.76:1

LUBRICANT

Type ----- A suffix A

Capacity (pts) -----

Dry ----- 19

Refill ----- 6.5

GOVERNOR

Type ----- Centrifugal

Operation ----- Regulates pump
oil pressure to automatic shift control valve

Drive ----- Mounted on output shaft

Location ----- In extension

OIL PUMPS

Type ----- Internal-external gear

Number ----- Two, front and rear

Function ----- To supply pressure

Front pump -----

Drive ----- Converter pump

Function ----- Supply main system
pressure at low vehicle speeds

The 1966-'67 427 Corvette was a hit

An egg crate grille and functional engine compartment cooling vents distinguished 1966 Corvettes. A new muscle Corvette was the "427" with its own funnel-shaped power bulge on the hood. There were two of these big-blocks at first. RPO L36, priced at \$181, was the 390-hp job. RPO L72, with a \$312

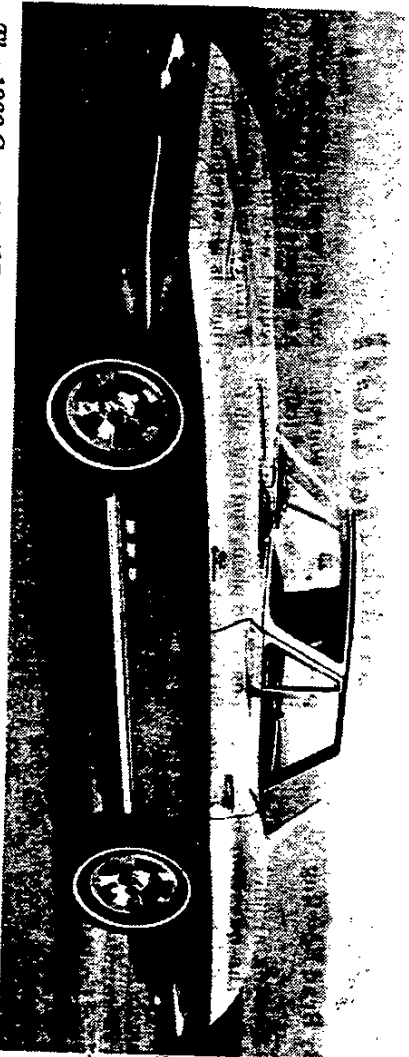

The 1966 Corvette 427 convertible with detachable hardtop.

price tag, delivered 425 hp. Both engines were related to the "mystery" 427 and the production Turbo-Jet 396.

The 427-powered convertible (425 hp) could hit 60 mph in 5.7 seconds and do the quarter mile in 14 seconds. It had a very favorable power-to-weight ratio of only 7.7 pounds-per-horsepower. For identification, "427 Turbo-Jet" crossed racing flag emblems appeared over the cooling vents. Three four-speed gearboxes—wide-ratio, close-ratio and heavy-duty close-ratio—were optional. A popular extra was side-mounted exhaust pipes.

Engine codes for 1966 big-blocks were IL for the regular L36, IM for the California air-

reactor version and IP for the L72. A total of 5,116 L36s were built and L72 production was 5,258 motors. Nearly 38 percent of the 1968 Corvettes were 427s.

For 1967, the Corvette got additional engine cooling vents and 427s got a different "power bulge" hood and more top horsepower. The new hood had a large forward-facing air scoop, usually with engine call-outs on both sides.

There were four versions of the 427 in 1967. The L36 was about the same. Next came the L68, with 400 hp and then the L71 with 435 hp. Extremely rare (only 20 built), and in a class by itself was the aluminum-headed L88. This powerhouse was officially rated at only 430 hp, but in

fact developed nearly 600! Depending on the mix of equipment, L36s were coded IL, IM, IQ, IR; L68s were coded JA, JC, JD, JF or JG and L88s had JU or JH codes. All L71s were stamped JE and all L88s were stamped IT. In all, 9,707 big-blocks were built, so 42.31 percent of all 1967 Corvettes were 427s!



SUPPLEMENTARY DATA

1967

PROTECT-O-PLATE DATA

Beginning with 1965 model year, owners of Chevrolet passenger cars received an embossed metal "Protect-O-Plate" after the purchase of their car that was to be attached the last page of the warranty booklet. The information on the plate was intended to give the dealer relevant production data about the car, but it can also be useful in determining a car's original equipment. Refer to the 1963-67 Addenda section for a complete plate translation table.

PAINT CODES

The 1967 Corvette paint codes functioned similarly to the 1966 codes; refer to the 1966 section for details.

Paint Code	Color	Interior Trim Restrictions
900AA	Black	None
972AA	White	None
974AA	Red	Black-red-white and black only
5AA	Bright Blue	Black-bright blue-white and bright blue only
7AA	Dark Blue	Black-dark blue-white and black only
980AA	Silver Blue	Black-dark blue only
983AA	Green	Black-saddle-green-white and black only
984AA	Yellow	Black-white and black only
986AA	Silver	Black-dark blue only
988AA	Maroon	Black-saddle-white and black only

BIG-BLOCK HOOD STRIPES

When we began research for this book, one of the mysteries we confronted was the hood stripes' color on 1967 big-block Corvettes. Why were the hood stripes painted white on some black cars, and red on other black cars? We were determined to get the answers and provide an accurate hood stripe color chart.

As we began to compile survey data, a pattern emerged. Four areas appeared to affect the color of the hood stripe: exterior (paint), trim (interior), hood stripe and tires. Tire colors were included, because they were available in three variations—blackwall, whitewall and redwall—which seemed to influence the stripe color. Results suggested that a red car with black tires would have a black stripe, while a red car with whitewalls had a white hood stripe. Likewise, the stripe color on a black body might be affected by the tires. With whitewalls, the hood stripe could be white, but with redline tires the hood stripe would be red. These conclusions appeared logical, and were corroborated with many examples. Occasionally, however, an exception to the tire color influence theory surfaced, leading us to question how many of our samples still had their original paint, tires and stripe?

We were particularly puzzled by two original '67s, a coupe and a convertible. We saw both cars months apart, yet both were comparable because they were triple-blue. That is, the body was blue, the interior was blue,

and the hood stripe was blue—all different shades of blue. The exterior was Silver Blue (980), the trim (interior) was Bright Blue (414), and the hood stripe was Dark Blue (977). The dark blue hood stripe was only a match against the Silver Blue hood. This color combination was rare and raised a question of authenticity, but both cars appeared to be untouched originals.

Fortunately, we were able to locate the original 1967 hood stripe color chart, and to our surprise the hood stripe color was determined by the exterior trim (interior) colors. The tire colors were incidental and had no influence on the hood stripe color.

Here, from Chevrolet's files, is the 1967 hood stripe color chart:

Exterior Color: 900AA Black

Hood Stripe Color	Interior Trim Color
Red	Black
Red	Red
White	Saddle
White	Green
White	White and Black
Dark Teal Blue	Dark Blue
Medium Bright Blue	Bright Blue
Medium Bright Blue	White and Bright Blue

Exterior Color: 972AA White

Hood Stripe Color	Interior Trim Color
Black	Black
Black	Saddle
Black	Green
Black	White and Black
Red	Red
Dark Teal Blue	Dark Blue
Medium Bright Blue	Bright Blue
Medium Bright Blue	White and Bright Blue

Exterior Color: 974AA Red

Hood Stripe Color	Interior Trim Color
Black	Black
Black	Red
White	White and Black

Exterior Color: 976AA Bright Blue (Manna Blue)

Hood Stripe Color	Interior Trim Color
Black	Black
Black	Bright Blue
White	White and Bright Blue

Exterior Color: 977AA Dark Blue (Lynndale Blue)

Hood Stripe Color	Interior Trim Color
Black	Black
Black	Dark Blue
White	White and Black

Exterior Color: 980AA Silver Blue (Elkhart Blue)

Hood Stripe Color	Interior Trim Color
Black	Black
Dark Teal Blue	Dark Blue

Exterior Color: 983AA Green

Hood Stripe Color	Interior Trim Color
Black	Black
White	Saddle
White	Green
White	White and Black

Exterior Color: 984AA Yellow

Hood Stripe Color	Interior Trim Color
Black	Black
Black	White and Black

Exterior Color: 986AA Silver

Hood Stripe Color	Interior Trim Color
Black	Black
Black	Dark Blue

Exterior Color: 988AA Maroon

Hood Stripe Color	Interior Trim Color
Black	Black
Black	Saddle
Black	White and Black

TRIM CODES

Trim code: 402
 Interior trim: Black Leather
 Exterior colors: No restrictions
 ECL: AA (no restrictions)

Trim code: 407
 Interior trim: Red Vinyl
 Exterior colors: 900-972-974
 ECLs: See table 1

Trim code: 408
 Interior trim: Red Leather
 Exterior colors: 900-972-974
 ECLs: See table 1

Trim code: 414
 Interior trim: Bright Blue Vinyl
 Exterior colors: 900-972-976
 ECLs: See table 1

Trim code: 415
 Interior trim: Bright Blue Leather
 Exterior colors: 900-972-976
 ECLs: See table 1

Trim code: 418
 Interior trim: Dark Blue Vinyl
 Exterior colors: 900-977-980-986
 ECLs: See table 1

Trim code: 419
 Interior trim: Dark Blue Leather
 Exterior colors: 900-977-980-986
 ECLs: See table 1

Trim code: 420
 Interior trim: Saddle Vinyl
 Exterior colors: 900-972-983-988
 ECLs: See table 1

Trim code: 421
 Interior trim: Saddle Leather
 Exterior colors: 900-972-983-988
 ECLs: See table 1

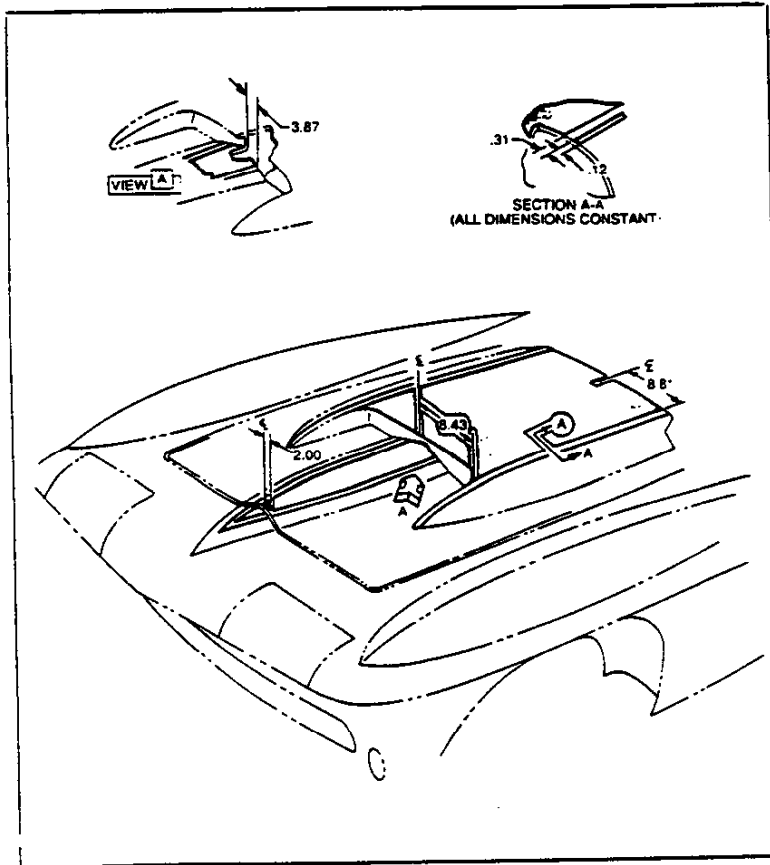

CORVETTE POWER TEAMS

Engine, Transmission and Rear Axle Combinations

ENGINE			REAR AXLE RATIOS							
			Without Air Conditioning				With Air Conditioning			
Option Number	Description	TRANSMISSION	Standard	Optional*			Standard	Optional*		
				Econ	Perf	Spec		Econ	Perf	Spec
Standard	300-hp Corvette V8 327-cu-in displacement 4-barrel carburetor Hydraulic lifters 10.0:1 compression ratio	3-Speed	▲ 3.36:1	3.08:1	—	—	▲ 3.36:1	3.08:1	—	—
		4-Speed Wide-Range								
		Powerglide	▲ 3.36:1	—	—	—	▲ 3.36:1	—	—	—
L79	350-hp Corvette V8 327-cu-in displacement 4-barrel carburetor Hydraulic lifters 11.0:1 compression ratio	4-Speed Wide-Range	▲ 3.36:1	—	3.55:1	—	▲ 3.36:1	—	3.55:1	—
		4-Speed Close-Ratio	▲ 3.70:1	—	4.11:1	—	▲ 3.70:1	—	4.11:1	—
L36	390-hp Turbo-Jet 427 V8 427-cu-in displacement Special camshaft Hydraulic lifters 10.25:1 compression ratio	4-Speed Wide-Range	* 3.08:1	—	3.36:1	—	* 3.08:1	—	3.36:1	—
		4-Speed Close-Ratio	* 3.36:1	3.08:1	3.55:1	3.70:1	* 3.36:1	3.08:1	3.55:1	3.70:1
		Powerglide ✓	* 3.36:1	3.08:1	3.55:1	3.70:1	* 3.08:1	—	—	—
L36/L68	400-hp Turbo-Jet 427 V8 427-cu-in displacement 3 x 2 barrel carburetors Special camshaft Hydraulic lifters 10.25:1 compression ratio	4-Speed Wide-Range	* 3.08:1	—	3.36:1	—	* 3.08:1	—	3.36:1	—
		4-Speed Close-Ratio	* 3.36:1	3.08:1	3.55:1	3.70:1	* 3.36:1	3.08:1	3.55:1	3.70:1
		Powerglide ✓	* 3.36:1	3.08:1	3.55:1	3.70:1	* 3.08:1	—	—	—
L71	435-hp Turbo-Jet 427 427-cu-in displacement 3 x 2 barrel carburetors Special camshaft Mechanical lifters 11.0:1 compression ratio	4-Speed Close-Ratio	* 3.55:1	3.36:1	3.70:1	4.11:1	Air Conditioning not available.			

* Available as Positraction only (RPO G81)

▲ Also available as Positraction (RPO G81)

CORVETTE

INVOICE INTERIOR TRIM IDENTIFICATION		
Black	Std	402
Bright Blue	414	415
Dark Blue	418	419
Green	430	
Red	407	408
Saddle	420	421
White/Black	455	
White/Bright Blue	450	

EXTERIOR SELECTION CHART

EXTERIOR COLORS	Code	INTERIOR TRIM COLORS							
		Black	Bright Blue	Dark Blue	Green	Red	Saddle	White/Black	White/Bright Blue
SOLID									
Tuxedo Black	AA	X	X	X	X	X	X	X	X
Ermine White	CC	X	X	X	X	X	X	X	X
Elkhart Blue	DD	X		X					
Lyndale Blue (Dk)	EE	X		X				X	
Marina Blue (Brt)	FF	X	X						X
Goodwood Green (Dk)	HH	X			X		X	X	
Marlboro Maroon	NN	X					X	X	
Rally Red	RR	X				X		X	
Silver Pearl	VV	X		X					
Sunfire Yellow	YY	X						X	

INTERIOR SELECTION CHART

TYPE OF SEAT	Material	Extra Cost	INTERIOR TRIM COLOR AVAILABILITY							
			Black	Bright Blue	Dark Blue	Green	Red	Saddle	White/Black	White/Bright Blue
SPORT COUPE AND CONVERTIBLE										
Bucket	Vinyl	No	E	R	B	X	D	C	S	W
Bucket	Leather	Yes	K	T	N		M	I		

Bright Blue—Carpet and Instrument Panel only.

Black—Carpet and Instrument Panel only.

CORVETTE

OPTIONS AND ACCESSORIES WHEN INSTALLED BY CHEV

Description	Ordering Col-Code	Option Number	Dealer Net	Fact D &
INTERIOR FEATURES				
Air Conditioning, Four-Season: Includes 61-amp Delcotron. Not available with 435-hp 427 engine.....	54-1	C60	\$297.92	\$20.9
Belt, Shoulder: Driver and passenger.....	4S-1	A85	19.00	1.5
Glass, Soft Ray Tinted: Windshield only.....	50-2	A02	7.60	.5
All windows.....	50-1	A01	11.40	.4
Headrests, Strato-Ease:				
Driver & passenger.....	57-2	A82	30.40	2.1
Radio, AM-FM:				
Pushbutton control (Includes rear fixed height antenna).....	46-5	U69	124.64	8.7
Speed Warning Indicator	43-2	U15	7.60	.5
Steering Shaft, Telescopic	52-2	N36	30.40	2.1
Trim Combinations: See Color and Trim chart				
Genuine leather seats.....	57.00	4.0
All other trims.....	N.C.	N.C.

HEAVY-DUTY AND OTHER EQUIPMENT

Brakes, Heavy-Duty: Available only when 427-cu-in engine and power brakes are ordered.....	37-3	J56	247.00	17.5
Exhaust System: Off-road service—available only when 3-speed or 4-speed transmission is ordered	41-1	N11	26.60	1.7
Exhaust System, Dual Side-Mounted: For off-road service only.....	41-2	N14	95.00	6.0
G.M. Air Injection Reactor: Approved by the state of California for vehicle registration.....	40-2	K19	32.30	2.0
Heater and Defroster Deletion: Not available when air conditioning is ordered.....	54-4	C48	69.75 CR.	4.0
Ignition System, Full-Transistor: Available only when optional engine is ordered. For detailed description see 1967 Finger-Tip Facts book.....	44-1	K66	53.20	3.0
Special Purpose Front & Rear Suspension: Includes special springs, matching shock absorbers and special front & rear stabilizer bars (available only when 435-hp engine is ordered).....	37-2	F41	26.60	1.0
Tank, Fuel: Model 19437 only (Capacity 36 gal). Also includes wheelhouse filler panel and a color-keyed fiber glass protective cover over tank in place of luggage compartment carpet.....	38-1	N03	142.88	10.0

FACTORY INSTALLED REGULAR PRODUCTION TIRES

Replaces 7.75-15/2-ply (4-ply rating) Original Equipment Blackwall				
(5) 7.75-15/2-ply (4-ply rating) Original Equipment Whitewall	34/3S-62	P92	22.80	
(5) 7.75-15/2-ply (4-ply rating) Special Nylon Red Stripes.....	34/3S-65	Q81	34.20	

◇ State and local taxes not included.

CORVETTE

1967 MODEL CORVETTE WITH STANDARD EQUIPMENT (300-hp Corvette V8 Engine—98" Wheelbase)

Model Description	List Price Less Invoice Discount (23%) †	List Price Less Base Discount (25%)	Factory D & H	List Price	Mfr's Suggested Dealer D & H	Mfr's Suggested Retail Price *	Destination Charge	Total
19437 Corvette Sport Coupe—2-passenger.....	\$3150.07	\$3068.25	\$222.00	\$4091.00	\$40.00	\$4353.00		
19467 Corvette Convertible—2-passenger With manually operated soft top.....	2995.30	2917.50	211.00	3890.00	40.00	4141.00		

† Base discount is 25% with the 2% difference retained for dealer's account in accordance with Terms of Sale Bulletin.
* Manufacturer's Suggested Retail Price does not include state and local taxes, license fees, options or accessories.

OPTIONS AND ACCESSORIES WHEN INSTALLED BY CHEVROLET

Description	Ordering Cal-Code	Option Number	Dealer Net	Factory D & H	List Price	Mfr's Suggested Retail Delivered Price †
POWER TEAMS						
<i>Engine: For transmission availability see Power Teams chart</i>						
350-hp Corvette 327 V8.....	30-3	L79	\$ 76.00	\$ 5.35	\$ 100.00	\$ 105.35
390-hp Corvette 427 V8—Available only when Positraction axle is ordered.....	30-4	L36	144.40	10.15	190.00	200.15
400-hp Corvette 427 V8—Available only when Positraction axle is ordered.....	30-9	L36/L68	220.40	15.50	290.00	305.50
435-hp Corvette 427 V8—Available only when Positraction axle, full-transistor ignition system and 4-speed close-ratio transmission are ordered.....	30-6	L71	315.40	22.10	415.00	437.10
<i>Transmission: See Power Teams chart for availability</i>						
4-Speed Manual (Wide-Range).....	29-3	M20	133.00	9.35	175.00	184.35
4-Speed Manual (Close-Ratio).....	29-5	M21	133.00	9.35	175.00	184.35
Powerglide.....	29-1	M35	140.60	9.85	185.00	194.85
<i>Axles, Positraction Rear: See Power Teams chart for availability</i>						
Std ratio.....	B	G81	30.40	2.15	40.00	42.15
3.08 ratio.....	BD	G81	30.40	2.15	40.00	42.15
3.36 ratio.....	BG	G81	30.40	2.15	40.00	42.15
3.55 ratio.....	BH	G81	30.40	2.15	40.00	42.15
3.70 ratio.....	BJ	G81	30.40	2.15	40.00	42.15
4.11 ratio.....	BL	G81	30.40	2.15	40.00	42.15

POWER ASSISTS						
Brakes, Power.....	33-2	J90	30.40	2.15	40.00	42.15
Steering, Power.....	33-1	N40	68.40	4.80	90.00	94.80
Windows, Power: Electric control.....	58-1	A31	41.80	2.95	55.00	57.95

EXTERIOR FEATURES						
Paint, Exterior: Solid colors only. See Color and Trim chart.....	N.C.	N.C.	N.C.	N.C.
Roof Cover, Vinyl: Black; available only when optional auxiliary top is ordered on model 19467.....	56-2	C08	38.00	2.70	50.00	52.70
<i>Top, Auxiliary: Hard top; Model 19467 only</i>						
In place of folding top.....	48-1	C07	N.C.	N.C.	N.C.	N.C.
In addition to folding top.....	48-2	C07	167.20	11.75	220.00	231.75
<i>Top, Folding: Model 19467 only. All tops available with all exterior colors</i>						
Black.....	55-2	C05	N.C.	N.C.	N.C.	N.C.
Blue.....	55-4	C05	N.C.	N.C.	N.C.	N.C.
White.....	55-1	C05	N.C.	N.C.	N.C.	N.C.
Wheels: Five cast-aluminum 15 x 6L.....	51-1	N89	190.00	13.30	250.00	263.30

⊕ State and local taxes not included.

MR. W. E. LUDWICK
OWNER RELATIONS DEPT.
CHEVROLET MOTOR DIVISION
1076 ARGO "A" BUILDING
DETROIT, MICHIGAN 48202

Origin No. DIS-63

C.O. No. 66-1158

Subject ADDITIONAL INFORMATION TO THE 1967
MODEL CHEVROLET MOTOR VEHICLE PRICE
SCHEDULES

NOV 25 1966



CHEVROLET MOTOR DIVISION
General Motors Corporation
Central Office
Detroit, Michigan 4820

To Zone Distribution Managers

Date November 22, 1966

Shown below is additional information affecting the 1967 Model Chevrolet Motor Vehicle Price Schedules which were attached to dealer letter dated October 14, 1966. Please advise dealers of this information asking that they make the necessary entries in all copies of the Price Schedules now in their possession.

SECTION III - PASSENGER CAR

CAMARO - Pages 28 and 30.

Availability of the optional Strato-Back Front Seat (RPO A14) ordering column 62, code 5, has been expanded to Sport Coupe Models with standard interior. This option may be ordered with black (code E), blue (code B), or gold (code G) interior trims.

Price remains unchanged.

Orders for this combination may now be submitted.

CORVETTE - Page 42.

Due to low volume usage, the optional 36 gallon fuel tank (RPO N03) has been cancelled and should no longer be ordered.

Very truly yours,

H. C. Wolfe

National Manager of Distribution

HCW/Lhr

cc: Mr. L. H. Averill
Assistant General Sales Managers
Regional Managers
Assistant Regional Managers
Zone Managers
Resident Comptrollers
Wholesale Organization
G. M. Assembly Division Plant Car Distributors
Mr. R. B. Calver - 10-137 G.M. Building
Mr. J. C. Salrin - A-163 G.M. Building

DIS-20
 C.O. No. 67-246
 Page 3

<u>Ordering</u>	<u>Opt.</u>	<u>Dealer</u>	<u>Factory</u>	<u>List</u>	<u>Mfr's. Sugg.</u>
<u>Col-Code</u>	<u>No.</u>	<u>Net</u>	<u>D&H</u>	<u>Price</u>	<u>Retail</u>
					<u>Del. Price</u>

(NEW OPTION) CORVETTE - Page 41.

ENGINE: 435 H.P. Corvette 427 V-8. Includes aluminum cylinder heads and chrome plated rocker covers. Available only when positraction axle, full transistor ignition system and 4 speed close-ratio transmission are ordered ----- 30-8 L71/L89 581.40 40.75 765.00 805.75

Power Teams for the above engine are identical to the 435 H.P. engine (RPO L71) shown on page 43 of the Vehicle Price Schedules.

Orders for this engine may now be submitted.

(NEW OPTION) C-P-S-T40 Series - Pages 29, 30, 32, 34 and 81.

STEERING, POWER: -----	67-2	N40	133.00	13.30	175.00	188.30
------------------------	------	-----	--------	-------	--------	--------

This option may now be ordered.

REVISION:

TE60 Series - Page 54.

Please insert the following prices on High-Tensile Steel Frame (RPO F02) as shown below.

TE61203-13 -----	171.00	17.10	225.00	242.10
TE61403-13 -----	190.00	19.00	250.00	269.00
TE61803-13 -----	209.00	20.90	275.00	295.90
TE62003-13 -----	228.00	22.80	300.00	322.80
TE62503-13 -----	247.00	24.70	325.00	349.70

The Corvette Black Book

1953-1993

October 1992

Published by

Michael Bruce Associates, Inc.
 Michael Antonick, President
 Post Office Box 396
 Powell, Ohio 43065



CONTENTS

Glossary	4	1965 Corvette	44	1981 Corvette	76
Instructions	6	1966 Corvette	46	1982 Corvette	78
Statistics	12	1967 Corvette	48	1984 Corvette	80
Chronology	14	1968 Corvette	50	1985 Corvette	82
1953 Corvette	20	1969 Corvette	52	1986 Corvette	84
1954 Corvette	22	1970 Corvette	54	1987 Corvette	86
1955 Corvette	24	1971 Corvette	56	1988 Corvette	88
1956 Corvette	26	1972 Corvette	58	1989 Corvette	90
1957 Corvette	28	1973 Corvette	60	1990 Corvette	92
1958 Corvette	30	1974 Corvette	62	1991 Corvette	94
1959 Corvette	32	1975 Corvette	64	1992 Corvette	96
1960 Corvette	34	1976 Corvette	66	1993 Corvette	98
1961 Corvette	36	1977 Corvette	68	Notes	100
1962 Corvette	38	1978 Corvette	70	Photos/Specs	104
1963 Corvette	40	1979 Corvette	72	Literature	124
1964 Corvette	42	1980 Corvette	74	Coupons	127

© Michael Bruce Associates, Inc., 1978, 1980, 1983, 1985, 1988, 1991, 1992. All rights reserved under Pan American and Universal Copyright Conventions by Michael Bruce Associates, Inc. Reproduction without permission is prohibited. Because of the possibility of errors, exceptions, or other reasons for inaccuracy, the publisher and author disclaim responsibility for the accuracy of any or all information presented in this publication.

Michael Bruce Associates, Inc. acknowledges with appreciation the following enthusiasts who contributed their expertise to this and previous editions of the *Corvette Black Book*: Roland Adams, Dan Aldridge, John Angwen, Pat Baker, Jane Barthelme, Michele Boring, Kent Brooks, Barry Brown, David Burroughs, Steve Dargemond, Dr. M. F. Dobbins, Bob Eckles, the late Sam Foltz, John Hibben, Mike Hunt, Alan Kaplan, Paul Kirchen, Gary Konner, Ralph Kramer and staff, Jim Krugroff, Gary Lisk, Bill Locke, Bob Lolewski, Bob McDorman, Chip Miller, Bill Mock, Brian Pearce, John Polorey, Bill Rhoads, Jeffrey Smith, Mark & Dixie Smith, Lou Vitale, Jerry Wadsworth, Jerry Weichers and Don Williams. Thanks also to Callaway Engineering, to Mercury-Marine, and to the Chevrolet Motor Division of General Motors Corporation.

Notice: The *Corvette Black Book* and its publisher, Michael Bruce Associates, Inc. have no relationship or connection whatever with Hearst Business Media Corporation, its parent or affiliated corporations, or the *Black Book* published by National Auto Research Division of Hearst Business Media Corporation.

Michael Bruce Associates, Inc. and the *Corvette Black Book* are not associated with or sponsored by General Motors or its Chevrolet Motor Division.

Cover: Photo and design by Mike Antonick. 1963 Corvette owned by Bill Munzer; restored by Bill Munzer and Don Williams.

Printed and bound in the United States of America.

ISBN: 0-933534-35-3

BOOK TRADE DISTRIBUTOR BY:



Oxford, Wisconsin 54021, USA

BLACK BOOK ORDER FORM

Send _____ copies of the

Corvette Black Book 1953-1993

@ \$11.95 each \$ _____

Ohio residents add .72 sales tax _____

Postage/hard shipping container _____ 3.00

Check or money order enclosed \$ _____

Name _____

Street _____

City _____ State _____ Zip _____

Mail Order To: Michael Bruce Associates, Inc.

Post Office Box 396

Powell, Ohio 43065

BLACK BOOK ORDER FORM

Send _____ copies of the

Corvette Black Book 1953-1993

@ \$11.95 each \$ _____

Ohio residents add .72 sales tax _____

Postage/hard shipping container _____ 3.00

Check or money order enclosed \$ _____

Name _____

Street _____

City _____ State _____ Zip _____

Mail Order To: Michael Bruce Associates, Inc.

Post Office Box 396

Powell, Ohio 43065



1967 CORVETTE

Production: 8,504 coupe, 14,436 convertible, 22,940 total.

1967 NUMBERS

Vehicle: 194377S100001 through 194377S122940

• For convertibles, fourth digit is a 6.

Suffix: HD: 327ci, 350hp, mt, ar IT: 427ci, 430hp (L88), mt
HE: 327ci, 300hp, mt IU: 427ci, 435hp, mt, ah
HH: 327ci, 300hp, mt, ar JA: 427ci, 435hp, mt, ar
HO: 327ci, 300hp, at JC: 427ci, 400hp, mt
HP: 327ci, 350hp, mt, ac, ps JD: 427ci, 400hp, at
HR: 327ci, 300hp, at, ar JE: 427ci, 435hp, mt
HT: 327ci, 350hp, mt JF: 427ci, 400hp, mt, ar
IL: 427ci, 390hp, mt JG: 427ci, 400hp, at, ar
IM: 427ci, 390hp, mt, ar JH: 427ci, 435hp, mt, ar, ah
IQ: 427ci, 390hp, at KH: 327ci, 350hp, mt, ar, ac, ps
IR: 427ci, 390hp, at, ar

Block: 3892657: 327ci 3869942: 427ci, ep, uu
3904351: 427ci 3916321: 427ci, lp, uu

Head: 3890462: 327ci, 300hp, 350hp 3904392: 427ci, 430hp, 435hp, ah
3904390: 427ci, 390hp, 400hp, ep 3909802: 427ci, 390hp, 400hp, lp
3904391: 427ci, 435hp, ih, ep 3919840: 427ci, 435hp, ih, lp

Carburetor: Holley R3418A: 427ci, 430hp (L88)
Holley R3659A: 427ci, 400hp, 435hp, fc, rc
Holley R3660A: 427ci, 400hp(cc,mt), 435hp(cc)
Holley R3810A: 327ci, 300hp, 350hp
Holley R3814A: 327ci, 300hp, 350hp, ar
Holley R3811A: 427ci, 390hp
Holley R3815A: 427ci, 390hp, ar
Holley R3888A: 427ci, 400hp, at, cc

Distributor: 1111117: 327ci, 300hp, at 1111141: 427ci, 390hp, ep
1111157: 327ci, 350hp, ig 1111240: 427ci, 430hp (L88)
1111194: 327ci, 300hp, mt 1111247: 427ci, 390hp, 400hp
1111196: 327ci, 350hp 1111248: 427ci, 390hp, 400hp, ig, ep
1111258: 427ci, 435hp, ig 1111294: 427ci, 390hp, 400hp, ig

Alternator: 1100693: 327ci, 427ci 1100696: 327ci, 427ci, ig
1100694: 327ci, 427ci, ac 1100750: 327ci, 427ci, ac, ig, uu

Ending Vehicle: Sep 66: 102110 Jan 67: 109465 May 67: 119747
Oct 66: 102685 Feb 67: 112264 Jun 67: 122214
Nov 66: 104981 Mar 67: 115316 Jul 67: 122940
Dec 66: 107110 Apr 67: 117395

Abbreviations: ac=air conditioning, ah=aluminum head, ar=air injection reactor, at=automatic transmission, cc=center carburetor, ci=cubic inch, ep=early production, fc=front carburetor, hp=horsepower, ig=transistor ignition, ih=iron head, lp=late production, mt=manual transmission, ps=power steering, rc=rear carburetor, uu=uncertain usage.

1967 FACTS

- Last of the 1963-67 "mid years," 1967's exterior was the least adorned due to removal of trim, including hood script emblems and fender flags. Functional fender vents were a new style for 1967 with five angled slots.
- Seat design was modified and the parking brake handle was redesigned and relocated from under the instrument panel to between the seats.
- Safety legislation required a modification of the knock-off wheel option. For 1967, it changed to a bolt-on, cast alloy style with a clip-on center cap to conceal the lug nuts. Rally wheels were no-cost standard equipment.



1967 OPTIONS

RPO #	DESCRIPTION	QTY	RETAIL \$
19437	Base Corvette Sport Coupe	8,504	\$4,388.75
19467	Base Corvette Convertible	14,436	4,240.75
—	Genuine Leather Seats	1,601	79.00
A01	Soft Ray Tinted Glass, all windows	11,331	15.80
A02	Soft Ray Tinted Glass, windshield	6,558	10.55
A31	Power Windows	4,036	57.95
A82	Headrests	1,762	42.15
A85	Shoulder Belts	1,426	26.35
C07	Auxiliary Hardtop (for convertible)	6,880	231.75
C08	Vinyl Covering (for auxiliary hardtop)	1,966	52.70
C48	Heater and Defroster Deletion (credit)	35	-97.85
C60	Air Conditioning	3,788	412.90
F41	Special Front and Rear Suspension	2,198	36.90
G81	Positraction Rear Axle, all ratios	20,308	42.15
J50	Power Brakes	4,766	42.15
J56	Special Heavy Duty Brakes	267	342.30
K19	Air Injection Reactor	2,573	44.75
K66	Transistor Ignition System	5,759	73.75
L36	427ci, 390hp Engine	3,832	200.15
L68	427ci, 400hp Engine	2,101	305.50
L71	427ci, 435hp Engine	3,754	437.10
L79	327ci, 350hp Engine	6,375	105.35
L88	427ci, 430hp Engine	20	947.90
L89	Aluminum Cylinder Heads for L71	16	368.65
M20	4-Speed Manual Transmission	9,157	184.35
M21	4-Speed Man Trans, close ratio	11,015	184.35
M22	4-Speed Man Trans, close ratio, heavy duty	20	237.00
M35	Powerglide Automatic Transmission	2,324	194.35
N03	36 Gallon Fuel Tank (for coupe)	2	198.05
N11	Off Road Exhaust System	2,326	36.90
N14	Side Mount Exhaust System	4,209	131.65
N36	Telescopic Steering Column	2,415	42.15
N40	Power Steering	5,747	94.80
N89	Cast Aluminum Bolt-On Wheels (5)	720	263.30
P92	Whitewall Tires, 7.75x15	13,445	31.35
QB1	Redline Tires, 7.75x15	4,230	46.65
U15	Speed Warning Indicator	2,108	10.55
U69	AM-FM Radio	22,193	172.75

• A 327ci, 300hp engine, 3-speed manual transmission, vinyl interior trim, and soft top (convertible) were included in the base price.

• The 6,880 C07 quantity included 895 in lieu of soft tops at no extra cost.

• The 3,788 C60 quantity was split 2,235 coupe, 1,553 convertible.

• The 2,324 M35 quantity was split 1,725 with 300hp engines, 392 with 390hp engines, and 207 with 400hp engines.

1967 COLORS

CODE	EXTERIOR	QTY	SOFT TOP	WHEELS	INTERIORS
900	Tuxedo Black	815	Bk-W-Tb	Silver	Bk-R-Bb-S-W-Tb-G
972	Ermine White	1,423	Bk-W-Tb	Silver	Bk-R-Bb-S-W-Tb-G
974	Rally Red	2,341	Bk-W-Tb	Silver	Bk-R-W
976	Marina Blue	3,840	Bk-W-Tb	Silver	Bk-Bb-W
977	Lynndale Blue	1,381	Bk-W-Tb	Silver	Bk-W-Tb
980	Elkhart Blue	1,096	Bk-W-Tb	Silver	Bk-Tb
983	Goodwood Green	4,293	Bk-W-Tb	Silver	Bk-S-W-G
984	Sunfire Yellow	2,325	Bk-W-Tb	Silver	Bk-W
986	Silver Pearl	1,952	Bk-W-Tb	Silver	Bk-Tb
988	Marlboro Maroon	3,464	Bk-W-Tb	Silver	Bk-W-S

• Suggested interiors shown. Other combinations were possible.

• In 1967, 10 Corvettes had non-standard paint, or primer.

Interiors: Std=Bk/V; 402=Bk/L; 407=R/V; 408=R/L; 414=Bb/V; 415=Bb/L; 418=Tb/V; 419=Tb/L; 420=S/V; 421=S/L; 450=W+B/V; 455=W+Bk/V.

Abbreviations: Bb=Bright Blue, Bk=Black, G=Green, L=Leather, R=Red, S=Saddle, Tb=Teal Blue, V=Vinyl, W=White.



AMA Specifications—Passenger Car

MAKE OF CAR CORVETTE MODEL YEAR 1967 DATE ISSUED 10-7-66 REVISED ^(*)

MODEL 19400 327 Cu. In. V-8
300 HP Standard | 350 HP
Opt. (L79) | 390 HP
Opt. (L36) | 427 Cu. In. V-8
400 HP
Opt. (L68) | 435 HP
Opt. (L71)

ENGINE—COOLING SYSTEM

Type system (pressure, pressure vented, atmospheric, other)		Pressure with surge tank		Pressure		
Radiator cap relief valve pressure				15 + 1 PSI		
Circulation thermostat	Type (choke, bypass)			Choke		
	Starts to open at (°F)			177° - 183°		
Water pump	Type (centrifugal, other)			Centrifugal		
	GPM @ 1000 pump rpm	57 @ 4400		82 @ 5200		
	Number of pumps			One		
	Drive (V-belt, other)			V-Belt		
	Bearing type			Double row ball		
By-pass recirculation type (internal, external)		Internal		External		
Radiator core type (cellular, tube and fin, other)				Cross flow		
Cooling system capacity	With heater (qt.)	16		23		
	Without heater (qt.)	15		22		
	Opt. equipment-specify (qt.)			-		
Water jackets full length of cylinder (yes, no)				Yes		
Water all around cylinder (yes, no)				Yes		
Radiator hose	Lower	Number and type (molded, straight)	One, molded			
		Inside diameter	1.75		1.88	
	Upper	Number and type (molded, straight)	One, molded			
		Inside diameter	1.50			
	By-pass	Number and type (molded, straight)	None	One, molded		
		Inside diameter	None	-		.725 - .765
Fan	Number of blades & spacing		5 Staggered			
	Diameter		17.12			
	Ratio-fan to crankshaft rev.		.949:1			
	Fan cutout type		Thermo-modulated-viscous coupling			
	Bearing type		Double row ball			
* Drive belts (indicate belt used by letter)	Fan	A	DE	HI		
	Generator or alternator	A	D	H		
	Water Pump	A	DE	HI		
	Power Steering	B	F	J	K	NA
	Air Conditioning	C	G	K	K	NA

* Drive Belt Dimensions	A	B	C	D	E	F	G	H	I	J	K
Angle of V					38°	-42°					
Nominal length (SAE)	53.25	36.25	57.50	54.00	34.40	45.00	56.75	56.00	34.40	45.00	45.75
Width					.380						

AMA Specifications—Passenger Car

MAKE OF CAR CORVETTE MODEL YEAR 1967 DATE ISSUED 10-7-66 REVISED (1)

GENERAL SPECIFICATIONS—DIMENSIONS

(All dimensions in inches unless otherwise indicated)
(Supplemental data available on request)

MODEL	SAE Ref. No.	19437 Coupe	19467 Soft-Top	19467 Hard-Top
-------	--------------	----------------	-------------------	-------------------

FRONT COMPARTMENT

Shoulder room	W3		48.4	
Hip room	W5		46.9	
Max. eff. leg room - accelerator	L34		42.7	
Effective head room	H61	37.0	38.5	37.2
H Point to Heel point	H30		7.3	

REAR COMPARTMENT - NOT APPLICABLE

Shoulder room	W4		---	
Hip room	W6		---	
Minimum effective leg room	L51		---	
Effective head room	H63		---	

LUGGAGE COMPARTMENT

Usable luggage capacity	V1	10.6		8.1
Liftover height	H195		---	
Position of spare tire storage		Under Fuel Tank (accessible from underside of vehicle)		
Method of holding lid open		Gravity		

STATION WAGON—THIRD SEAT - NOT APPLICABLE

Hip room	WB6		---	
Effective leg room	B6		---	
Effective head room	HB6		---	
Seat facing direction			---	

STATION WAGON—CARGO SPACE - NOT APPLICABLE

MODEL	SAE Ref. No.			
Minimum distance between wheel houses at floor level	W201		---	
Rear end opening width at belt	W204		---	
Floor length from back of front seat at floor level to inside of closed tail gate	L202		---	
Minimum horizontal distance from top rear of front seat back to inside of tail gate at belt	L204		---	
Maximum height - floor covering to headlining at centerline of rear axle	H201		---	
Maximum height of rear opening - tail and lift gates open	H202		---	
Cargo volume index (cu. ft.)	$\frac{W4 \times L204 \times H201}{1728}$	V2		---

AMA Specifications—Passenger Car

MAKE OF CAR	CORVETTE		MODEL YEAR	1967	DATE ISSUED	10-7-66	REVISED	(*)
MODEL	19400	327 Cu.In. V-8 300 HP Standard	350 HP Opt (L79)	390 HP Opt (L36)	427 Cu.In. V-8 400 HP Opt (L68)	435 HP Opt (L71)		

ENGINE—GENERAL

Type, no. cyls., valve arr.	90° OHV V-8				
Bore and stroke (nominal)	4.00 x 3.25		4.25 x 3.76		
Piston displacement, cu. in.	327		427		
Bore spacing (C/L to C/L)	4.4		4.84		
No. system (front to rear)	L. Bank	1-3-5-7			
	R. Bank	2-4-6-8			
Firing order	1-8-4-3-6-5-7-2				
Compres. ratio (nominal)	10:0:1	11.0:1	10.25:1	11.0:1	
Cylinder Head Material	Cast alloy iron				
Cylinder Block Material	Cast alloy iron				
Cylinder Sleeve-Wet, dry, none	None				
Number of mounting points	Front	Two			
	Rear	One			
Engine installation angle	3°				
Taxable horsepower	51.2		57.8		
Publishing max. bhp* @ eng. RPM	300 @ 5000	350 @ 5800	390 @ 5400	400 @ 5400	435 @ 5800
Publishing max. torque* (lb. ft. @ RPM)	360 @ 3400	360 @ 3600	460 @ 3600	460 @ 3600	460 @ 4000
Recommended fuel regular - premium	Premium				
Idle speed (spec. neutral or drive)	Manual	500 in neutral	700 in neutral	550 in neutral	750 in neutr.
	Automatic	500 in drive	NA	550 in drive	NA

ENGINE—PISTONS

Material	Cast al. alloy		(a)	Cast aluminum alloy		(a)
Description and finish	Flat notched head		Domed head, valve cutout			
Weight (piston only) oz.	21.60		20.64	28.00	24.67	
Clearance (limits)	Top land	.0365-.0455	.0395-.0425	.0305-.0375	.0265-.0335	
	Skirt	Top	.0005-.0011(b)	.0024-.0030(c)	.0009-.0015 (d)	.0040-.0046(c)
Ring groove depth	Bottom					
	No. 1 ring	.2217-.2283		.2348-.2413		
	No. 2 ring	.2217-.2283		.2348-.2413		
	No. 3 ring	.2038-.2103		.2183-.2248		.2133-.2148
	No. 4 ring	None				

* Max. bhp (brake horsepower) and max. torque corrected to 60° F and 29.92 in. Hg atmospheric pressure.

- (a) Aluminum impact extruded
- (b) Measured 2.24 from top of piston
- (c) Measured 2.20 from top of piston
- (d) Measured 1.89 from top of piston

AMA Specifications—Passenger Car

MAKE OF CAR CORVETTE MODEL YEAR 1967 DATE ISSUED 10-7-66 REVISED (01)

POWER TEAMS

(Indicate whether standard or optional)

MODEL AVAILABILITY	ENGINE					TRANSMISSION	AXLE RATIO **				
	Displ. cu. in.	Carburetor	Compr. Ratio	BHP @ RPM	Torque @ RPM		(Std. first)	(Indicate A/C ratio)	A	B	C
19400	327 300 HP	4-Bbl	10.0:1	300 @ 5000	360 @ 4000	3-Spd (2.54:1 low)	3.36	3.08	--	--	--
						4-Spd*(2.52:1 low)					
						Powerglide*					
						Air/Cond.*364-Spd					
						Air/Cond.*Pwr/Gld					
	327 350 HP*	4-Bbl	11.0:1	350 @ 5800	360 @ 3600	4-Spd*(2.52:1 low)	3.36	--	3.55	--	--
						4-Spd*(2.20:1 low)					
						Air/Cond*(2.52:1)					
						Air/Cond*(2.20:1)					
	427 390 HP*	4-Bbl	10.25:1	390 @ 5400	460 @ 3600	4-Spd*(2.52:1 low)	3.36	3.08	3.55	3.7	--
						4-Spd*(2.20:1 low)					
						Powerglide*					
						Air/Cond*(2.52:1)					
						Air/Cond*(2.20:1)					
	427 400 HP*	3 x 2 Bbl	10.25:1	400 @ 5400	460 @ 3600	4-Spd*(2.52:1 low)	3.36	3.08	3.55	3.7	--
						4-Spd*(2.20:1 low)					
						Powerglide*					
						Air/Cond*(2.52:1)					
						Air/Cond*(2.20:1)					
	427 435 HP*	3 x 2 Bbl	11.0:1	435 @ 5800	460 @ 4000	4-Spd*(2.52:1 low)	3.36	3.08	3.55	3.70	4.1
4-Spd*(2.20:1 low)											
<p>A - Standard B - Economy - Optional C - Performance - Optional D - Special Purpose - Optional * - Optional ** - Positraction axles available optionally for all 327 Cu. In. engines with standard axles. All other engine-axle combinations are available as positraction only.</p>											

AMA Specifications—Passenger Car

MAKE OF CAR	CORVETTE	MODEL YEAR	1967	DATE ISSUED	10-7-66	REVISED	(1)
MODEL	19400	327 Cu. In. V-8	300 HP	350 HP	427 Cu. In. V-8	390 HP	400 HP
		Standard	Opt (L79)	Opt (L36)	Opt (L68)	Opt (L71)	435 HP

ENGINE—RINGS

Function (top to bottom)	No. 1, oil or comp.	Compression					
	No. 2, oil or comp.	Compression					
	No. 3, oil or comp.	Oil					
	No. 4, oil or comp.	None					
Compression	Description - Upper material, coating, etc.	Cast alloy iron; inside bevel on 327 cu.in.; no bevel on 427 cu.; chrome plate coating on 327(300HP); Molybdenum inlay on remainder					
	Lower	Chrm plate on 327(350HP) & 427(435HP); remainder wr.resistant ctr					
	Width	(a)	(b)	.0770-.0775			
	Gap	.013-.023	(c)	.010-.020			
Oil	Description - material, coating, etc.	Multi-piece (2 rails and one spacer expander) Rails-steel, chrome plated OD Expander - stainless steel					
	Width	.1870-.1890					
	Gap	.015-.055		.010-.030			
Expanders	In oil ring assembly						

ENGINE—PISTON PINS

Material		Chromium Steel					
Length		2.990-3.010			2.930-2.950		
Diameter		.9270-.9273			.9895-.9898		
Type	Locked in rod, in piston, floating, etc.	Locked in rod					
	Bushing	None					
	Material						
Clearance	In piston	.00015-.00025	.00045-.00055	.00025-.00035		.00030-.00040	
	In rod	None					
Direction & amount offset in piston		(d)	On center	(d)	On center		

ENGINE—CONNECTING RODS

Material		Drop forged steel				High alloy steel	
Weight (oz.)		21.60		20.64		28.00	
Length (center to center)		5.699-5.701				6.130-6.140	
Bearing	Material & Type	Premium Aluminum					
	Overall length	.807			.857		
	Clearance (limits)	.0007-.0027			.0009-.0029		.0014-.0034
	End play	.009-.013			.016-.020		

- (a) - Upper .0775-.0780; Lower .0770-.0775
 (b) - Upper .0770-.0775; Lower .0775-.0780
 (c) - Upper .010-.020; Lower .013-.023
 (d) - Major thrust side .055-.065

AMA Specifications—Passenger Car

MAKE OF CAR	CORVETTE	MODEL YEAR	1967	DATE ISSUED	10-7-66	REVISED (a)
MODEL	19400	327 Cu. In. V-8 300 H.P. Standard	350 H.P. Opt. (L79)	427 Cu. In. V-8 390 H.P. Opt. (L36)	400 H.P. Opt. (L68)	435 H.P. Opt. (L71)

ENGINE—CRANKSHAFT

Material		Forged steel			
Vibration damper type		Rubber mounted inertia			
End thrust taken by bearing (No.)		Five			
Crankshaft end play		.006-.010			
Main bearing	Material & type		Premium aluminum except No. 5 is sintered copper nickel backed babbitt. (Premium aluminum on lower (#5) 327-300 HP)		
	Clearance		(a)	(b)	(c)
	Journal dia. and bearing overall length	No. 1	2.3003 x .752	2.7507 x .992	2.7510 x .992
		No. 2	2.3004 x .752	2.7507 x .992	2.7510 x .992
		No. 3	2.3004 x .752	2.7505 x .992	2.7505 x .992
		No. 4	2.3004 x .752	2.7505 x .992	2.7505 x .992
		No. 5	2.3009 x 1.177	2.7506 x 1.2525	2.7506 x 1.2525
	No. 6		None		
No. 7		None			
Dir. & amt. cyl. offset		None			
Crankpin journal diameter		1.999 - 2.000		2.199 - 2.200	

ENGINE—CAMSHAFT

Location		In block above crankshaft		
Material		Cast alloy iron		
Bearings	Material	Steel backed babbitt		
	Number	Five		
Gear or chain		Chain		
Type of Drive	Crankshaft gear or sprocket material	Steel sprocket		
	Camshaft gear or sprocket material	Cast aluminum		
	Timing chain	No. of links	50	
Width		.880		
Pitch		.500		

ENGINE—VALVE SYSTEM

Hydraulic lifters (Std, opt, NA)		Standard	NA
Valve rotator, type (Intake, exhaust)		None	
Rocker ratio		1.50:1	1.70:1
Operating tappet clearance (Indicate hot or cold)	Intake	Zero	.024
	Exhaust	Zero	.028
Timing marks on flywheel, damper, other		Torsional damper	

- (a) - #1 - (.0008-.0020); #2, 3 & 4 - (.0008-.0024) (Continued) #5 - (.0015 - .0031)
 (b) - #1 & 2 - (.0010-.0022); #3 & 4 - (.0013-.0025); #5 - (.0015-.0031)
 (c) - #1, 2, 3 & 4 - (.0013-.0025); #5 - (.0015-.0031)

AMA Specifications—Passenger Car

MAKE OF CAR	CORVETTE		MODEL YEAR	1967	DATE ISSUED	10-7-66	REVISED (*)
MODEL	19400	327 Cu. In. V-8	350 HP	390 HP	427 Cu. In. V-8	400 HP	435 HP
		Standard	Opt. (L79)	Opt. (L36)	Opt. (L68)	Opt. (L71)	

ENGINE—VALVE SYSTEM (cont.)

Timing *	Intake	Opens (°BTC)	38°	54°	56°	44°	
		Closes (°ABC)	92°	108°	114°	92°	
Duration - deg.	310°	342°	350°	316°			
Exhaust	Opens (°BBC)	88°	102°	110°	86°		
	Closes (°ATC)	52°	60°	62°	36°		
	Duration - deg.	320°	342°	352°	302°		
Valve opening overlap		90°	114°	118°	80°		
Intake	Material		Alloy steel; aluminized face; also chrome flash stem on L71 & L79				
	Overall length		4.870 - 4.889	5.215 - 5.235	5.204 - 5.224		
	Actual overall head dia.		1.935-1.945	2.017-2.023	2.060 - 2.070	2.185-2.195	
	Angle of seat & face		46° (seat) 45° (face)				
	Seat insert material		None				
	Stem diameter		.3410 - .3417	.3715 - .3722			
	Stem to guide clearance		.0010 - .0027	.0010 - .0027			
	Lift (@ zero lash)		.3900	.4472	.4614	.5197	
	Outer spring press. and length	Valve closed (lb. @ in.)	76-84 @ 1.70		94-106 @ 1.88		
		Valve open (lb. @ in.)	180-192 @ 1.25		303-327 @ 1.38		
	Inner spring press. and length	Valve closed (lb. @ in.)	Spring damper				
		Valve open (lb. @ in.)	Spring damper				
	Exhaust	Material		High alloy steel; aluminized face; also chrome flash stem on L71 &			
		Overall length		4.913-4.933	4.891-4.910	5.345 - 5.365	
Actual overall head dia.		1.495-1.505	1.595-1.605	1.715 - 1.725			
Angle of seat & face		46° (seat) 45° (face)					
Seat insert material		None					
Stem diameter		.3410 - .3417	.3713 - .3720				
Stem to guide clearance		.0015 - .0032					
Lift (@ zero lash)		.4100	.4472	.4800	.5197		
Outer spring press. and length		Valve closed (lb. @ in.)	76-84 @ 1.70		94-106 @ 1.88		
		Valve open (lb. @ in.)	180-192 @ 1.25		303-327 @ 1.38		
Inner spring press. and length		Valve closed (lb. @ in.)	Spring damper				
		Valve open (lb. @ in.)	Spring damper				

ENGINE—LUBRICATION SYSTEM

Type of lubrication (splash, pressure, nozzle)	Main bearings	Pressure
	Connecting rods	Pressure
	Piston pins	Splash
	Camshaft bearings	Pressure
	Tapets	Pressure
	Timing gear or chain	Centrifugally oiled from camshaft bearing
	Cylinder walls	Pressure, jet cross sprayed

(Continued)

* - Values for all engines except 435 HP include ramps
 Values for 435 HP are given with lash of .024 intake and .028 exhaust

AMA Specifications—Passenger Car

Page 8

Page

MAKE OF CAR	CORVETTE	MODEL YEAR	1967	DATE ISSUED	10-7-66 REVISED ^(*)	
MODEL	19400	327 Cu. In. V-8 300 H.P. Standard	350 H.P. Opt. (L79)	390 H.P. Opt. (36)	427 Cu. In. V-8 400 H.P. Opt. (L68)	435 H.P. Opt. (L7)

ENGINE—LUBRICATION SYSTEM (cont.)

Oil pump type		Gear	
Normal oil pressure (lb. @ engine rpm)	30-45 PSI @ 1500		50-75 PSI @ 2000
Oil pressure sending unit (elect. or mech.)	Mechanical (direct pressure to Bourdon tube)		
Type oil intake (floating, stationary)	Stationary		
Oil filter system (full flow, partial, other)	Full flow		
Filter replacement (element, complete)	Element		
Capacity of crankcase, less filter-refill (qt.)	4		5
Oil grade recommended (SAE viscosity and temperature range)	* 32° F. and above - SAE 20W, SAE 10W-30 0° F. to 032° F.* - SAE 10W or SAE 10W-30 Below 0° F. - SAE 5W or SAE 5W-20 *(SAE 5W-30 may be used at temperature below freezing)		
Engine Service Requirement (MM, MS, etc.)	MS or DG		

ENGINE—EXHAUST SYSTEM

Type (single, single with cross-over, dual, other)	Dual		
Muffler No. & type (reverse flow, straight thru, separate resonator)	Two, reverse flow		
Exhaust pipe dia. (O.D., wall thickness)	Branch	2.50 x .067 - .081 (a)	2.50 x .072 - .092
	Main	2.50 x .084 - .104 laminated (b)	
Tail pipe diameter (O.D. & wall thickness)	2.00 x .023		

ENGINE—CRANKCASE VENTILATION SYSTEM

Type (ventilates to atmo., induction system, other)	Standard	Induction System
	Optional	
Control Unit	Make and model	
	Location	Carburetor Base
	Energy source (manifold vacuum, carburetor air stream, other)	Carburetor air stream
Complete system	Control method (variable orifice, fixed orifice, other)	Fixed orifice
	Discharges to intake manifold, carb. air intake, air cleaner intake, other)	Intake manifold
	Air inlet (breather cap, carburetor air cleaner, other)	Filtered side of air cleaner
	Flame arrestor (screen, check valve, other)	Screen

(a) 2.00 diameter on Powerglide
 (b) .067 - .081 wall thickness on 327 Cu. In. Powerglide

AMA Specifications—Passenger Car

MAKE OF CAR CORVETTE MODEL YEAR 1967 DATE ISSUED 10-7-66 REVISED ^(*)

MODEL 19400 327 Cu. In. V-8 427 Cu. In. V-8
300 HP 350 HP 390 HP 400 & 435 HP
Mnl. Tr. | P/G Tr. Mnl. Tr. Mnl. Tr. | P/G Tr. Mnl. Tr. | P/G Tr. *

ENGINE—EXHAUST EMISSION CONTROL

Type (Air injection, engine modifications, other)		Air Injection						
Air Injection Pump	Type	Semi-articulated vane type						
	Displacement	19.3 cubic inches						
	Drive ratio	1.25:1						
	Drive type	Crankshaft pulley						
	Relief valve (type)	Pressure (plate type)						
Filter (describe)		None (clean air drawn from air cleaner)						
Air Injection System	Air distribution (head, manifold, etc.)	Manifold						
	Point of entry	Exhaust ports						
	Injection tube I.D.	.2565						
	Check valve type	Pressure (plate type)						
Backfire protection (type)		Vacuum actuated, anti-backfire valve						
Carburetor	Make	Holley						
	Model	3906635		3906637		(a)		
	Barrel size	1.562 Primary & Secondary				1.50 Prim: 1.75 Sec.		
	Idle speed	Drive	-	600	-	-	550	-
		Neutral	700	-	750	700	-	750
Aux. Adv. Systems (type)		None						
Distributor	Make	Delco Remy						
	Model	1111194	1111117	1111196	1111247	1111247	1111258(c)	
	Cam'fgal adv. in crank degrees @ eng. rpm.	Start (rpm)	900					
		Informed. points deg. @ rpm	15@1500	25@1500	15@1500	17 @ 2000		None
		Max. deg. @ rpm.	30@5100	40@5100	30@5100	32 @ 5000		30@3800
	Vacuum adv. in. crank degrees @ eng. rpm	Start (in Hg)	6		4		7	
Informed. points deg. @ in. Hg		None						
Max. deg. @ in.		15 @ 12		16@7		12 @ 12		15@15.5
Vacuum Source		Carburetor						
Timing - Crank degrees @ rpm @ Idle		6 BTDC	4 ATDC	10 BTDC	4 BTDC		5 BTDC	
Cooling System (describe changes)		195° Thermostat						
Exhaust System (describe changes)		None						

* Available with 400 HP engine only

(a) 3 x 2 Carburetor - Two Secondary #3902353; One Primary #3902355

(b) Model 1111247 is used with 400 HP Mnl. Trans. & P/G Trans.

(c) Model 1111258 (Transistorized) used with 435 HP only

AMA Specifications—Passenger Car

MAKE OF CAR CORVETTE MODEL YEAR 1967 DATE ISSUED 10-7-66 REVISED ^(*)

MODEL 19400 327 Cu. In. V-8
300 H.P. Standard 350 H.P. Opt. (L79) 390 H.P. Opt. (L36) 427 Cu. In. V-8
400 H.P. Opt. (L68) 435 H.P. Opt. (L71)

ENGINE—FUEL SYSTEM

(See supplemental page for Details of Fuel Injection, Supercharger, etc. if used)

Induction type: Carburetor, fuel injection, supercharger.

		Carburetor
Fuel Tank	Refill capacity (gals.)	20 (approximately)
	Filler location	Center at rear deck
Fuel Pump	Type (elec. or mech.)	Mechanical
	Locations	Lower right front of engine
	Pressure range	5.25 - 6.50 PSI 5.00 - 6.50 PSI
Vacuum booster (std., optional, none)		None
Fuel Filter	Type	Fine mesh plastic strainer in gas tank
	Locations	and sintered bronze filter in carburetor inlet
Carburetor	Choke type	Automatic
	Intake manifold heat control (exhaust or water)	Exhaust
	Air cleaner type	Standard: Oil-wetted paper element Polyurethane Optional:

CARBURETOR SUPPLEMENTARY INFORMATION

Model Usage	Engine Displ.	Transmission	Carburetors		No. Used and Type	Barrel Size
			Make	Model		
19400	327 300hp	3-Spd & 4-Spd Powerglide	Holley	3906631	One; 4-Bbl	1.561 Prim & Sec
	327 350hp	4-Spd.	Holley	3906631	One; 4-Bbl	1.561 Prim & Sec
	427 390hp	4-Spd. Powerglide	Holley	3906633	One; 4-Bbl	1.561 Prim & Sec
	427 400hp	4-Spd. Powerglide	Holley	3902355 (Prim.) 3902353 (Secondary)	Three; 2-Bbl (1-Prim) (2-Sec.)	Prim 1.50 Sec. 1.75
	427 435hp	4-Spd.	Holley	3902355 (Prim.) 3902353 (Secondary)	Three; 2-Bbl. (1-Prim) (2-Sec.)	Prim. 1.5 Sec. 1.7

AMA Specifications—Passenger Car

MAKE OF CAR CORVETTE MODEL YEAR 1967 DATE ISSUED 10-7-66 REVISED ^(*)

MODEL 19400 327 Cu. In. V-8
300 HP Standard 350 HP
Opt. (L79) 427 Cu. In. V-8
390 HP Opt. (L36) 400 HP
Opt. (L68) 435 HP
Opt. (L71)

ENGINE—COOLING SYSTEM

Type system (pressure, pressure vented, atmospheric, other)		Pressure with surge tank		Pressure			
Radiator cap relief valve pressure				15 ± 1 PSI			
Circulation thermostat	Type (choke, bypass)			Choke			
	Starts to open at (°F)			177° -183°			
Water pump	Type (centrifugal, other)			Centrifugal			
	GPM @ 1000 pump rpm	57 @ 4400		82 @ 5200			
	Number of pumps			One			
	Drive (V-belt, other)			V-Belt			
	Bearing type			Double row ball			
Bypass recirculation type (internal, external)		Internal		External			
Radiator core type (cellular, tube and fin, other)				Cross flow			
Cooling system capacity	With heater (qt.)	16		23			
	Without heater (qt.)	15		22			
	Opt. equipment-specify (qt.)			-			
Water jackets full length of cylinder (yes, no)				Yes			
Water all around cylinder (yes, no)				Yes			
Radiator hose	Lower	Number and type (molded, straight)	One, molded				
		Inside diameter	1.75		1.88		
	Upper	Number and type (molded, straight)	One, molded				
		Inside diameter	1.50				
	Bypass	Number and type (molded, straight)	None		One, molded		
		Inside diameter	None		.725 - .765		
Fan	Number of blades & spacing		5 Staggered				
	Diameter		17.12				
	Ratio-fan to crankshaft rev.		.949:1				
	Fan cutout type		Thermo-modulated-viscous coupling				
	Bearing type		Double row ball				
*Drive belts (indicate belt used by letter)	Fan		A	DE	HI		
	Generator or alternator		A	D	H		
	Water Pump		A	DE	HI		
	Power Steering		B	F	J	J	NA
	Air Conditioning		C	G	K	K	NA

* Drive Belt Dimensions	A	B	C	D	E	F	G	H	I	J	K
Angle of V					38°	-42°					
Nominal length (SAE)	53.25	36.25	57.50	54.00	34.40	45.00	56.75	56.00	34.40	45.00	45.75
Width						.380					

AMA Specifications—Passenger Car

MAKE OF CAR CORVETTE **MODEL YEAR** 1967 **DATE ISSUED** 10-7-66 **REVISED** (10)
MODEL 19400 327 Cu. In. V-8 | 350 HP | 390 HP | 427 Cu. In. V-8 | 435 HP
Standard | Opt. (L79) | Opt. (L36) | Opt. (L68) | Opt. (L7)

ELECTRICAL—SUPPLY SYSTEM

Battery	Make and Model		Delco-Remy #1980030			
	Voltage Rtg. & Total Plates		12 Volt - 66 Plate			
	SAE Designation & Amp Hr. Rtg.		61 Amp/Hr @ 20 Hr Rate			
	Location		Right rear engine compartment			
Terminal grounded		Negative				
Generator or Alternator	Make		Delco-Remy			
	Model		#1100693			
	Type and rating		Diode rectified 9-37 Amps			
	Output at engine idle (neutral)		13amps	22amps	16amps	24amps
Ratio—Gen. to Cr/s rev.		2.46:1				
Regulator	Make		Delco-Remy			
	Model		119515			
	Type		Vibrator			
	Cutout relay	Closing voltage @ generator rpm	None			
		Reverse current to open	None			
	Regulated	Voltage	13.8 - 14.8 @ 85°F			
Current						
Voltage test conditions	Temperature	Operating				
	Load	3-8 amps				
	Other	None				

ELECTRICAL—STARTING SYSTEM

Starting motor	Make		Delco-Remy			
	Model		1107320		1107365	
	Rotation (drive end view)		Clockwise			
	Engine cranking speed					
	Test conditions		Engine at operating temperature			
No load test	Amps	65-100		70-99		
	Volts	10.6		10.6		
	RPM (min)	3600-5100		7800-12000		
Motor control	Switch (solenoid, manual)		Solenoid			
	Starting procedure		<p>3-Spd & 4-Spd-Place gear shift in neutral & depress clutch to floor. Powerglide -Place control lever in "N" or "P" position Initial Start - Press accelerator pedal to floor once to set automatic choke, then release. Turn ignition to 'START', release as soon as engine starts.</p>			

(Continued)

AMA Specifications—Passenger Car

MAKE OF CAR CORVETTE MODEL YEAR 1967 DATE ISSUED 19-7-66 REVISED #1
 MODEL 19400 327 Cu. In. V-8 390 HP 427 Cu. In. V-8 435 HP
 Standard 350 HP Opt. (L79) Opt. (L36) 400 HP Opt. (L68) Opt. (L71)

ELECTRICAL—STARTING SYSTEM (cont.)

Motor Drive	Engagement type		Positive shift solenoid		
	Pinion meshes (front, rear)		Rear		
	Number of teeth	Pinion	9		
		Flywheel	Manual	153	168
	Flywheel tooth face width	Manual	153	NA	168
Auto.			.4010-.4130	.4100-.4220	NA

ELECTRICAL—IGNITION SYSTEM

Coil	Transistorized - Std., Opt., N.A.		Optional		Mandato	
	Make		Delco-Remy			
	Model		1115202	1115264	1115210	
Amps	Engine stopped		4.0			
	Engine idling		1.8			
Distributor	Make		Delco-Remy			
	Model		1111194	1111196	1111247	1111258
	Cent'igal adv. in crankshaft degrees @ engine rpm (nominal)	Start (rpm)	900			
		Intermediate points deg. @ rpm.	15 @ 1500	17 @ 2000	None	
		Max. deg. @ rpm.	30 @ 5100	32 @ 5000	30@3800	
	Vacuum adv. in crankshaft degrees @ in. Hg. (nominal)	Start (in. Hg.)	6	4	7	8
		Intermediate points, deg. @ in. Hg.	None			
		Max. deg. in. Hg.	15@12	16@7	12@12	15@15.5
	Breaker gap (in.)		.019 (new)			Trans.
	Cam angle (deg.)		28 - 32			Magnetic
Breaker arm tension (oz.)		19 - 23oz.			Pulse	
Timing	Crankshaft deg. @ rpm.		(a)	(b)	4 BTDC @ 550 (c)	
	Mark location		Torsional damper			
Spark Plug	Make		AC Spark Plug			
	Model		AC 44	AC43N		
	Thread (mm)		14			
	Tightening torque (lb. ft.)		25			
	Gap		.033 - .038			
Cable	Conductor type		Linen core impregnated with electrical conducting material			
	Insulation type		Rubber with neoprene jacket			
	Spark plug protector		Hypalon jacket			

- (a) 6° BTDC @ 500
 (b) 10° BTDC @ 700
 (c) 5° BTDC @ 750

AMA Specifications—Passenger Car

MAKE OF CAR CORVETTE MODEL YEAR 1967 DATE ISSUED 10-7-66 REVISED ⁽¹⁾

MODEL 19400 327 Cu. In. V-8 350 HP Standard | 350 HP Opt. (L79) | 390 HP Opt. (L36) | 427 Cu. In. V-8 400 HP Opt. (L68) | 435 HP Opt. (L71)

ELECTRICAL—SUPPRESSION

Locations & type	Non-Metallic High Tension Ignition Cables
------------------	--

ELECTRICAL—INSTRUMENTS AND EQUIPMENT

Speedometer	Make	AC
	Trip odometer (yes, no)	Yes
Charge indicator—type		Ammeter
Temperature indicator—type		Electric gage
Oil pressure indicator—type		Bourdon tube gage
Fuel indicator—type		Electric gage
Other		Mechanical tachometer
Windshield wiper	Make	Delco products
	Type—Standard	Electric two-speed
	Type—Optional	None
	Vacuum booster provision	None
	Washer provision	Pushbutton - standard
Horn	Type	Vibrator
	Number used	2
	Amp draw (each)	(Low note) 4.5-6.3@12.5V. (Hi note) 4.2-6.2@12.5V

DRIVE UNITS—CLUTCH (Manual Transmission) 3-Speed & 4-Speed

Make & type	Chevrolet, single dry disc, centrifugal		
Type pressure plate springs	Circular plate diaphragm, bent finger design		
Total spring load (lb.)	2100-2300	2450-2750	2600-2800
No. of clutch driven discs	One		
Clutch facing	Material	Woven type asbestos	
	Outside & inside dia.	11.0 - 6.5	
	Total eff. area (sq. in.)	123.70	
	Thickness	.135 each	
	Engagement cushioning method	Flat spring steel between cushions	
Release bearing	Type & method of lubrication	Single row ball, packed and sealed	
Torsional damping	Methods: springs, friction material	Coil springs	

AMA Specifications—Passenger Car

MAKE OF CAR	CORVETTE	MODEL YEAR	1967	DATE ISSUED	10-7-66	REVISED (a)
MODEL	19400	327 Cu. In. V-8 300 HP Standard	350 HP Opt. (L79)	390 HP Opt. (L36)	427 Cu. In. V-8 400 HP Opt. (L68)	435 HP Opt. (L7)

DRIVE UNITS—TRANSMISSIONS

Manual 3-speed (std. or opt.)	Standard - available with 300 HP only
Manual 4-speed (std. or opt.)	Optional
Manual with overdrive (std. or opt.)	Not available
Automatic (std. or opt.)	Powerglide optional with 300 HP & 390 & 400 HP only

DRIVE UNITS—MANUAL TRANSMISSION

Number of forward speeds	3-Speed (a)	4-Speed (b)	4-Speed (c)	
	3	4	4	
Transmission ratios	In first	2.54	2.20	
	In second	1.50	1.64	
	In third	1.00	1.27	
	In fourth	-	1.00	
	In reverse	2.63	2.59	2.26
Synchronous meshing, specify gears	All forward gears			
Shift lever location	Floor mounted			
Lubricant	Capacity (pt.)	3		
	Type recommended	Military spec. MIL-L-2105-B		
	SAE viscosity number	Summer	SAE80	
		Winter	SAE80	
	Extreme cold	SAE80		

DRIVE UNITS—MANUAL TRANSMISSION WITH OVERDRIVE

For transmission data see manual transmission section			
Type (planetary or other)			
Manual lockout (yes, no)			
Downshift accelerator control (yes, no)			
Minimum cut-in speed	Not		
Gear ratio	Available		
Lubricant	Capacity (pt.) (Overdrive only)	Available	
	Separate filler (yes, no)		
	Type recommended		
	SAE viscosity number	Summer	
Winter			
Extreme cold			

- (a) - Available with 327 Cu. In. 300 HP only
- (b) - Available with all engine combinations
- (c) - Available all engine combinations except 327 Cu. In. (300 HP)

AMA Specifications—Passenger Car

MAKE OF CAR CORVETTE MODEL YEAR 1967 DATE ISSUED 10-7-66 REVISED 00

MODEL 19400

DRIVE UNITS—AUTOMATIC TRANSMISSION

Available with 327 Cu. In. (300 HP) & 427 Cu. In. (390 & 400 HP) only

Trade name	Powerglide	
Type describe	Torque converter with planetary gears	
Method of Selection (Lever, Push Button or other)	Lever (floor mounted)	
Selector Pattern	P-R-N-D-L	
List gear ratios Selector Pattern and indicate which are used in each selector position	Drive 1.76 and 1.0 Low & Reverse 1.76	
Max. upshift speeds—drive range	67 (327 Cu. In.); 76 (427 Cu. In.)	
Max. kickdown speeds—drive range	64 (327 Cu. In.); 72 (427 Cu. In.)	
Torque converter	Number of elements	3
	Max. ratio at stall	2.10
Lubricant	Type of cooling (air, liquid)	Air
	Capacity—refill (qt.)	6.5
Special transmission features	Type recommended	A suffix A

DRIVE UNITS—PROPELLER SHAFT

Number used	One	
Type (exposed, torque tube)	Tubular, exposed	
Outer diameter x length* x wall thickness	Manual 3-speed transmission	2 x 29.90 x .095
	Manual 4-speed transmission	2 x 29.90 x .095
	Overdrive transmission	NA
	Automatic transmission	2 x 29.90 x .095

* Center to center of universal joints, or to centerline of rear attachment.

(Continued)

AMA Specifications—Passenger Car

MAKE OF CAR CORVETTE MODEL YEAR 1967 DATE ISSUED 10-7-66 REVISED (1)

MODEL 19400

DRIVE UNITS—PROPELLER SHAFT (cont.)

Inter- mediate bearing	Type (plain, anti-friction)	None
	Lubrication (fitting, prepack)	Prepack
Universal joints	Make	Chevrolet
	Number used	Two
	Type (ball and trunnion, cross, other)	Cross
	Bearing	Type (plain, anti-friction)
Lubric. (fitting, prepack)		Prepack
Drive taken through (torque tube or arms, springs)		Torque Control Arms
Torque taken through (torque tube or arms, springs)		Torque Control Arms

DRIVE UNITS—REAR AXLE

Description	Semi-floating, overhung pinion gear		
Limited Slip differential, type	Dual Disc Clutches		
Drive Pinion Offset	1.5		
No. of differential pinions	2		
Ring gear O.D. (std. ratio)	8.375		
Pinion adjustment (shim, other)	None		
Pinion bearing adj. (shim, other)	Shim		
Wheel bearing type	2-Taper Roller		
Lubricant	Capacity (pt.)	3.7	
	Type recommended	Military specs MIL-L-2105-B	
	SAE vis- cosity number	Summer	SAE 80
		Winter	SAE 80
		Extreme cold	SAE 80

REAR AXLE RATIO TOOTH COMBINATIONS

(See page 4 for axle ratio usage)

Axle ratio		3.36:1	3.70:1	3.08:1	3.55:1	4.11:1
No. of teeth	Pinion	11	10	12	9	9
	Ring gear	37	37	37	32	37

AMA Specifications—Passenger Car

MAKE OF CAR CORVETTE MODEL YEAR 1967 DATE ISSUED 10-7-66 REVISED ^(*)MODEL 19400

DRIVE UNITS—WHEELS

Type & material	Short spoke disc, steel	
Rim (size and flange type)	Std.	15 x 6 JK
	Opt.	15 x 6L Ribbed, cast aluminum
Attachment	Type (bolt or stud)	Bolt
	Circle diameter	4.75
	Number and size	5 Hex nuts 7/16 - 20 UNF 2-B

DRIVE UNITS—TIRES

Standard (List option below)	Size & ply	7.75 x 15 - 4PR
	Type - Nylon, etc.	Original equipment
Rev/mile at 50 mph.		776
Inflation press. (cold)	Front	24
	Rear	24
Optional tires - size and ply		---

BRAKES—SERVICE

Type (dual-servo, disc, balanced, etc.)		Caliper Disc, 4-wheel hydraulic	
Self adjusting (std., opt., N.A.)		Standard	
Hydraulic system type (single, dual, etc.)		Dual	
Power brake make & type (remote, integral, etc.)		Delco-Moraine vacuum power unit assists master cylinder; integral unit	
Effective area (sq. in.) *		78.1	
Gross lining area (sq. in.) **		86.3	
Swept drum area (sq. in.) ***		461.2	
Percent brake effectiveness—front		65.0	
Drum or Rotor	Diameter	Front	Disc 11.75
		Rear	Disc 11.75
Type and material	Type and material		Cast Iron
	Rotor (vented or solid)		Vented
	No. pistons per caliper		4
Wheel cyl- inder bore	Front	1.875	
	Rear	1.375	
Master cylinder bore		1.00	
Available pedal travel		5.00	
Line pressure at 100 lb. pedal load		576	
Shoe clearance adjustment		Self-adjusting	

(Continued)

* Excludes rivet holes, grooves, chamfers, etc.

** Includes rivet holes, grooves, chamfers, etc.

*** Total swept area for four brakes:

Widest lining contact width for each brake x its drum circumference.

AMA Specifications—Passenger Car

MAKE OF CAR CORVETTE MODEL YEAR 1967 DATE ISSUED 10-7-66 REVISED 01

MODEL 19400

BRAKES—SERVICE (cont.)

Brake lining	Drum or Disc		Disc	
	Bonded or riveted		Riveted	
	Front Wheel	Material	Woven asbestos	
		Size (length x width x thickness)	Prim. or out-board	5.96 x 2.21 x .41
			Second. or in-board	5.96 x 2.21 x .41
	Segments per shoe		One	
	Rear Wheel	Material	Woven asbestos	
		Size (length x width x thickness)	Prim. or out-board	5.96 x 2.21 x .41
Second. or in-board			5.96 x 2.21 x .41	
Segments per shoe		One		

BRAKES—PARKING

Type of control	Mechanical	
Location of control	Grip handle on center floor console	
Operates on	Rear wheels	
If separate from service brakes	Type (internal or external)	Internal
	Drum diameter	6.5
	Lining size (length x width x thickness)	6.78 x 1.25 x .175

FRAME

Type and description (Separate frame, unitized frame, partially-unitized frame)	All welded, full length, ladder constructed frame with 5 crossmembers
---	---

STEERING

Manual (std., opt., NA)	Standard				
Power (std., opt., NA)	Optional				
Adjustable steering wheel (tilt, swing, other)	Type and description (std., opt., NA)	Telescopic steering column; 3" adjustment			
		Optional			
Wheel diameter	Manual	16.0			
	Power	16.0			
Turning diameter	Outside front	Wall to wall (l. & r.)	41.6		
		Curb to curb (l. & r.)	39.9		
	Inside rear	Wall to wall (l. & r.)	25.6		
		Curb to curb (l. & r.)	25.6		
Outside wheel angle with inside wheel at 20°		18.5			
Manual	Gear	Type	Semi-reversible, recirculating ball nut		
		Make	Saginaw		
	Ratios	Gear	16:1		
		Overall	Street	20.2:1	Fast
No. wheel turns		Street	3.4	Fast	2.92

(Continued)

AMA Specifications—Passenger Car

MAKE OF CAR CORVETTE MODEL YEAR 1967 DATE ISSUED 10-7-66 REVISED 00

MODEL _____

STEERING (cont.)

Power	Type (coaxial, linkage, etc.)		Linkage
	Make		Saginaw
	Gear	Type	Same as Manual
		Ratios	16.0:1
		Gear Overall	17.6:1
	Pump driven by		Crankshaft pulley
Number wheel turns		2.92	
Linkage	Type		Parallelogram
	Location (front or rear of wheels, other)		Rear
	Drag link (trans. or length.)		None
	Tie rods (one or two)		Two
Steering Axis	Inclination or camber (deg.)		6-1/2 to 7-1/2
	Bearings (type)	Upper	Ball stud with non-metallic bearing surfaces
		Lower	Ball stud with non-metallic bearing surfaces
		Thrust	None
Wheel Alignment (range of curb weight and preferred)	Caster (deg.)		P 1/2 to P 1 1/2
	Camber (deg.)		P 1/4 to P 1 1/4 (a)
	Toe-in (outside track inches)		3/16 to 5/16 (a)
Steering spindle & joint type			Steering knuckle with spherical joint
Wheel spindle	Diameter	Inner bearing	1.2493 - 1.2498
		Outer bearing	.7492 - .7497
	Thread size		3/4 - 20 NEF - 3 (Mod)
	Bearing type		Taper roller

(a) Rear Wheel Alignment; Camber (Deg.) N 1 to 0
Toe-In (Total) 1/16 to 3/16.

AMA Specifications—Passenger Car

MAKE OF CAR CORVETTE MODEL YEAR 1967 DATE ISSUED 10-7-66 REVISED ⁽⁸⁾

MODEL 19400

SUSPENSION—GENERAL

(See Supplemental page for details on Air Suspension)*

Provision for car leveling	Front stabilizer bar
Provision for brake dip control	Mounting angle of front upper control arm
Provision for ecc. squat control	Rear suspension geometry
Special provisions for car jacking	Front: 5" forward of front edge of door opening, under frame Rear: 3" forward of wheel opening, under frame.
Shock absorber front & rear	Type Make Piston dia.
	Direct, double-acting hydraulic Delco 1.00
Other special features	Fully independent rear suspension.

SUSPENSION—FRONT

Type and description	Independent: SLA type with coil spring and concentric shock absorber, and Spherically - Jointed steering knuckle for each wheel	
Spring	Type	Coil
	Material	Steel alloy
	Size (coil design height & I.D.; bar length x dia.)	8.56 x 3.80 168.50 x .600
	Spring rate (lb. per in.)	195
	Rate at wheel (lb. per in.)	80
Stabilizer	Type (link, linkless, frameless)	Link
	Material & bar diameter	327 V-8 steel .750 427 V-8 steel .875

SUSPENSION—REAR

Type and description	(A)	
Drive and torque taken through	Torque control arms	
Spring	Type	Multi-leaf
	Material	Chrome carbon steel
	Size (length x width, coil design height & I.D.; bar length & dia.)	46.36 x 2.25
	Spring rate (lb. per in.)	140
	Rate at wheel (lb. per in.)	123
	Mounting insulation type	Rubber mtd, at diff.; Vertical loading only at shackles
	If leaf	No. of leaves Shackle (comp. or tons)
Stabilizer	Type (link, linkless, frameless)	Link (B)
	Material	.562
Track bar type	None	

(A) Full independent with fixed differential, transverse multi-leaf spring, lateral struts and universally-jointed axle shafts.

AMA Specifications—Passenger Car

MAKE OF CAR CORVETTE MODEL YEAR 1967 DATE ISSUED 10-7-66 REVISED ⁽¹⁾

MODEL 19400 19437 19467

BODY—MISCELLANEOUS INFORMATION

Doors hinged (front, rear)	Front doors	Front
	Rear doors	NA
Type of finish (lacquer, enamel, other)		Lacquer
Hood counterbalanced (yes, no)		No
Hood release control (internal, external)		Internal
Vehicle Ident. No. location		1 - Right side of hinge pillar cross brace, under glove box 2 - With engine number.
Engine No. location		Front right side of cylinder block
Theft protection - type		Outside door key locks
Vent window control method (crank, friction pivot)	Front	Crank
	Rear	NA
Seat cushion type	Front	Bucket-polyurethane padding
	Rear	NA
	3rd seat	NA
Seat back type	Front	Bucket-polyurethane padding
	Rear	NA
	3rd seat	NA
Windshield glass type (i.e., single curved - laminated plate)		Single curved-laminated safety plate
Side glass type (i.e., curved - tempered plate)		Compound curved -solid safety plate
Backlight glass type (i.e., compound curved - tempered plate, three piece)		19467 soft top, flat flexible plastic, 1-piece 19467 hard top, curved plexiglass, 1-piece 19437 compound curved solid safety plate, 1-piece
Windshield glass exposed surface area		789.7
Side glass exposed surface area	620.1	550.1
Backlight glass exposed surface area	821.5	440.5
Total glass exposed surface area	2231.5	1780.3

LAMP HEIGHT AND SPACING

Height above ground to center of bulb	Headlamp	Highest *	24.4
		Lowest	24.4
	Tail	Highest	21.2
		Lowest	21.2
Distance from C/L of car to corner of bulb	Headlamp	Inside	15.4
		Outside *	21.7
	Tail	Inside	19.0
		Outside	24.0
	Directional	Front	28.3
		Rear	Inboard 19.0 Outboard 24.0

* If single headlamps are used enter here.

AMA Specifications—Passenger Car

MAKE OF CAR CORVETTE MODEL YEAR 1967 DATE ISSUED 10-7-66 REVISED ^(M)

MODEL 19437 19467

CONVENIENCE EQUIPMENT

(Indicate whether standard, optional or NA on each series)

Power windows	Side Windows	Optional
	Vent Windows	NA
	Becklight or tailgate	NA
Power seats (specify type as well as availability)		NA
Reclining front seat back		NA
Front seat headrest		Optional
Radios (specify type as well as availability)		AM-FM push-button, all models
Rear seat speaker		NA
Power Antenna		NA
Clock		Standard
Air Conditioner (specify type and availability)		Four seasons, all models
Speed warning device		Optional
Speed control device		NA
Ignition lock lamp		Standard
Beck up lamp		Standard
Dome lamp		Standard NA
Glove compartment lamp		Standard
Pkg. brake signal lamp		Standard
Luggage compartment lamp		NA
Underhood lamp		NA
Courtesy lamp		Standard
Map lamp		NA
Auto. wans. quad. lamp		NA
Emergency flasher lamp, Four-way		Standard
Cornering light lamp		NA
Freeway lane change signal		Standard
Instrument panel pad		Standard
Left hand outside mirror		Standard
Padded sunshades		Standard
Brake system warning and parking brake light		Standard
Steering column energy absorbing		Standard

INDEX

SUBJECT	PAGE NO.	SUBJECT	PAGE NO.
Automatic Transmission	1, 16	Linings - Clutch, Brake	14, 18, 19
Axis, Steering	20	Lubrication	7, 8, 14, 15, 16, 17
Axis, Rear	1, 17	Luggage Capacity	2
Battery	12	Motor, Starting	12
Bearings, Engine	5, 6, 7	Muffler	8
Belts - Fan, Generator, Water Pump	11	Overdrive	15
Body - General Information, types	Title, 1, 2, 22	Piston Pins & Rings	3, 5
Exterior Dimensions	1	Pistons	3, 5
Interior Dimensions	2	Power Brakes	18
Brakes - Parking, Service, Power	18, 19	Power Steering	19
Camber	20	Power Teams	4
Camshaft	6	Propeller Shaft, Universal Joints	16, 17
Capacities		Pumps - Oil, Fuel	8, 10
Cooling System	11	Water	11
Fuel Tank	10	Radiator, Hoses	11
Lubricants		Ratios - Axle	1, 4, 17
Engine Crankcase	8	Compression	1, 3, 4
Transmission and Overdrive	15, 16	Steering	19, 20
Rear Axle	17	Transmission	15, 16
Carburetor	4, 9, 10	Rear Axle	1, 4, 17
Caster	20	Regulator - Generator	12
Choke, Automatic	10	Rims	18
Clutch - Pedal Operated	14	Rings, Piston	5
Coil, Ignition	13	Rods - Connecting	5
Connecting Rods	5	Shock Absorbers, Front & Rear	21
Convenience Equipment	23	Spark Plugs	13
Cooling System	11	Speedometer	14
Crankcase Ventilation	8	Springs - Front & Rear Suspension	21
Crankshaft	5	Valve, Engine	6
Cylinders and Cylinder Head	3	Stabilizer (Sway Bar) - Front & Rear	21
Distributor - Ignition	13	Starting Motor	12
Electrical System	12, 13, 14	Steering	19, 20
Engine		Suppression - Ignition, Radio	14
Bore, Stroke, Displacement, Type	1, 3	Suspension - Front & Rear	21
Compression Ratio	1, 3	Tailpipe	8
Firing Order, Cylinder Numbering	3	Thermostat, Cooling	11
General Information, H.P. & Torque	1, 3	Timing, Engine & Valve	6, 7, 13
Lubrication	7, 8	Tires	1, 18
Power Teams	4	Tee in	20
Exhaust Emission Control	9	Torque Converter	16
Exhaust System	8	Torque - Engine, Retd.	1, 3, 4
Equipment Availability	22	Transmission - Types	1, 4, 10, 15, 16
Fan, Cooling	11	Automatic	1, 4, 10, 15, 16
Filters - Engine Oil, Fuel System	8, 10	Manual & Overdrive	1, 4, 10, 15
Frame	19	Ratios	15, 16
Front Suspension	21	Track	1
Fuel, Fuel Pump, Fuel System	1, 3, 10	Trunk Luggage Capacity	2
Fuel Injection	1, 10	Turning Diameter	19
Generator and Regulator	12	Unitized Construction	19
Glass	22	Universal Joints, Propeller Shaft	16, 17
Height (Lamps)	14	Valves - Intake & Exhaust	6, 7
Headroom - Body	2	Vibration Damper	6
Weights - Overall	1	Voltage Regulator	12
Horns	14	Water Pump	11
Horsepower - Brake	1, 3, 4	Weights - Shipping, Curb	24
Ignition System	13	Wheel Alignment	20
Inflation - Tires	18	Wheelbase	1
Instruments	8, 14	Wheels & Tires	18
Kingspin (Steering Axis)	20	Wheel Spindle	20
Lamp Height & Spacing	22	Widths - Car & Body	1
Lugroom	2	Windshield	22
Lengths - Overall	1	Windshield Wiper	14
Lifters, Valve	6		